

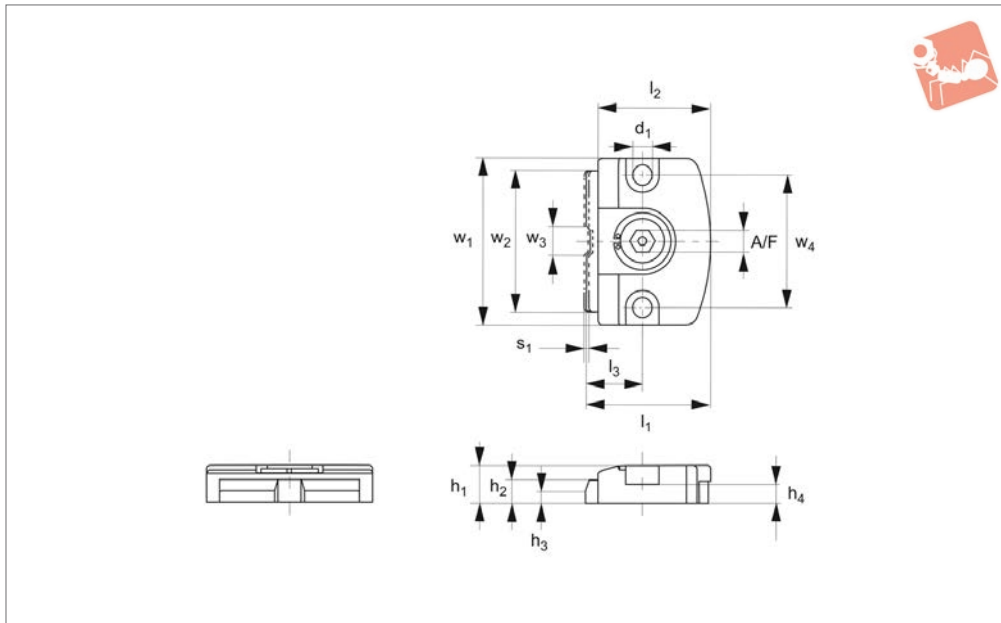

Low Profile Cam Edge Clamps

hex drive

Low Profile Side Clamping



10980.1

LOW PROFILE SIDE CLAMPING

Material

Body: steel (C45), black oxide finish.
Jaw/cam: steel (42CrMo), tempered, black oxide finish.

Technical Notes

Designed to prevent part lift.

Turning the wrench allows the cam to move the jaw forward for clamping. When the wrench is turned back for unclamping, the loaded spring allows the jaw to return to the original position.

Tips

Ensure that mounting surfaces are finished to 6.3a or better, without any scratches or dents.

Order No.	Clamping stroke s_1	d_1	l_1	l_2	l_3	h_1	h_2	h_3	h_4	w_1	w_2	w_3	w_4	Torque to Nm max.	A/F	Clamping force kN max.	Weight g
10980.W0038	1	5.2	33.5	30.5	15	10	6	3	5	45	38	8	36	10	6	4	85
10980.W0060	2	8.2	50.0	46.0	22	15	9	5	7	70	60	12	55	27	10	6	290

