

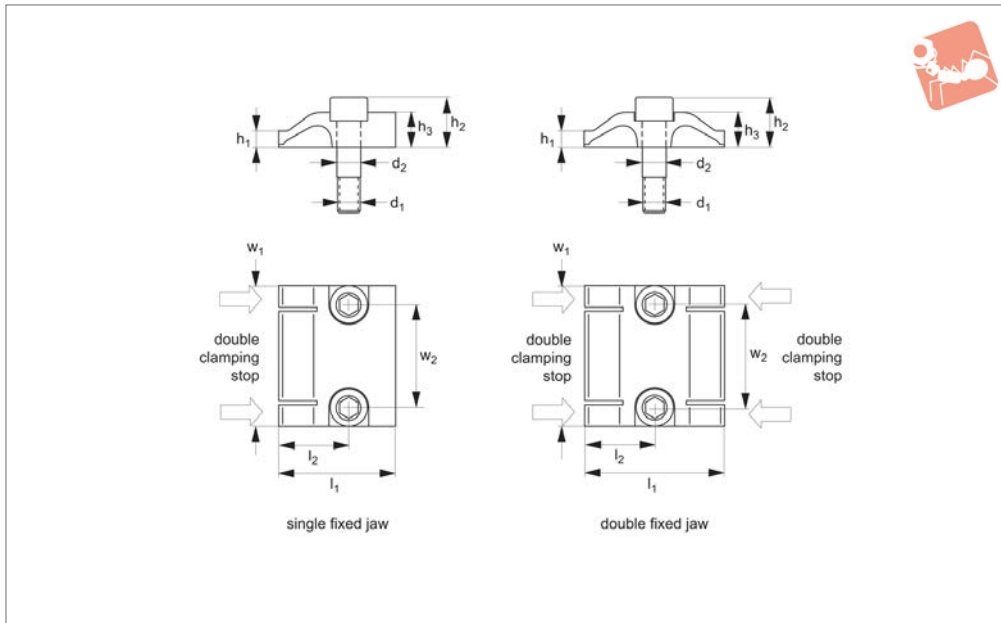

1.2 Ton Fixed Stops for finger clamps

Heavy-Duty Side Clamping



11071

HEAVY-DUTY SIDE CLAMPING

Material

Spring steel.

Technical Notes

These stops have a unique sideways and

downwards action.

Tips

Provided with specially ground location bolts $\varnothing 10,2 - M10$. For mounting there are

2 tapped holes at $44,00 \pm 0,005\text{mm}$ centres, M10 with depth of 28mm, counterbore 10,2 (H6) with depth of 14mm.

Order No.	Type	Clamping height h_1	d_1	d_2	h_2	h_3	l_1	l_2	w_1	w_2
11071.W0080	Single	7	M10	10.2	22	15	50	30	60	44
11071.W0082	Double	7	M10	10.2	22	15	60	30	60	44

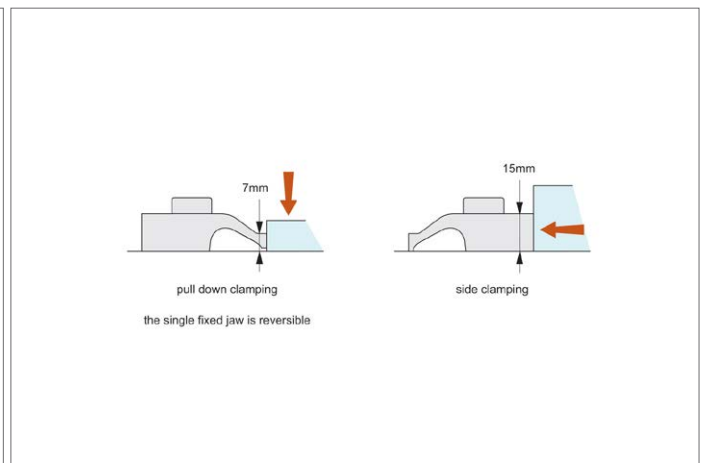
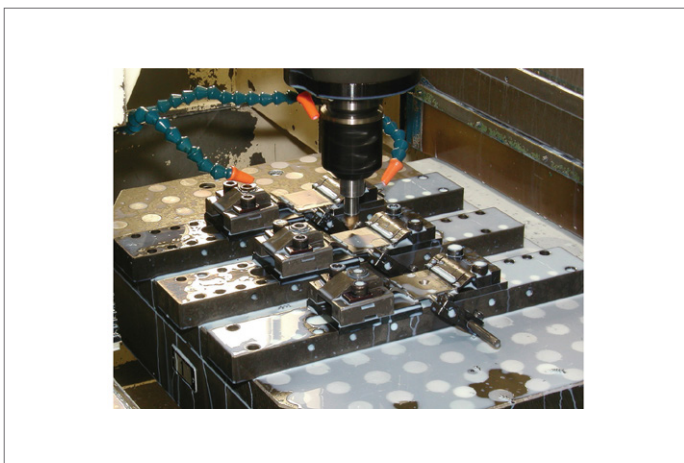



Application

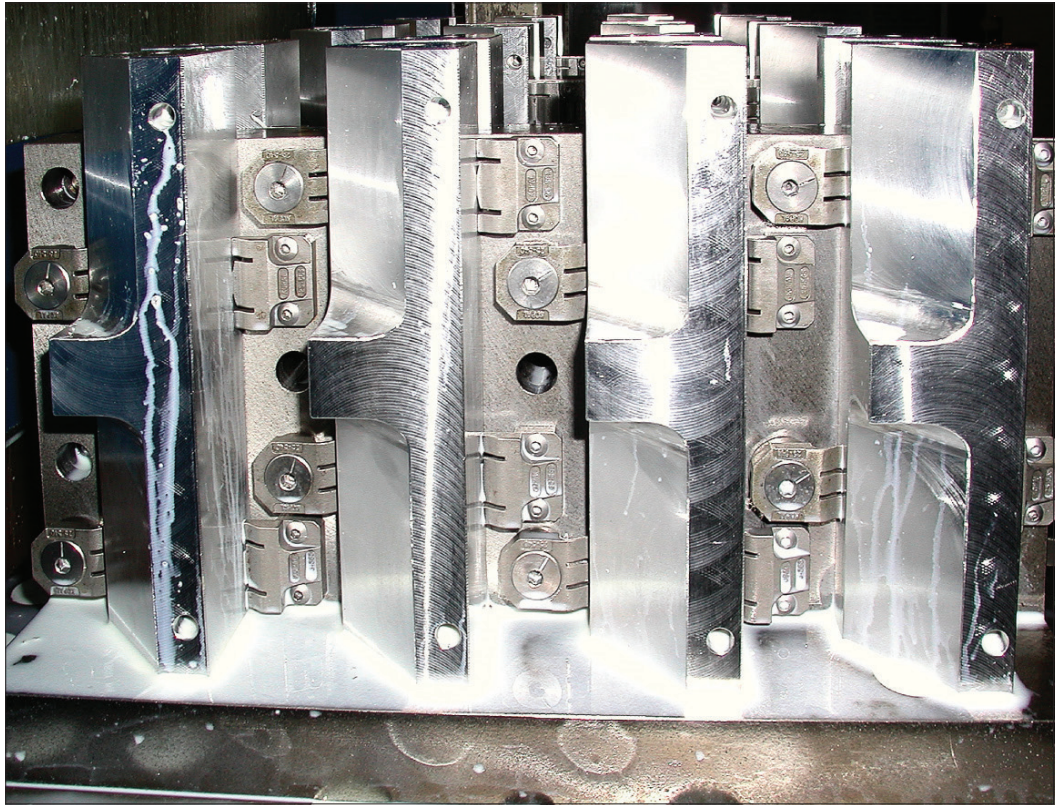

HEAVY-DUTY SIDE CLAMPING

Unique Horizontal Clamping Set-Ups

Part No. 10900, 10920, 10940
T-slot table and special machining set-ups



Part No. 11040, 11041, 11042, 11043
Supports and special machining set-ups

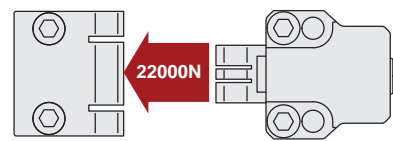

Part No. 11070, 11071
Supports and special machining set-ups

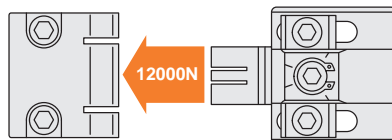

Part No. 11080, 11081, 11083
T-slot table, supports and special machining set-ups

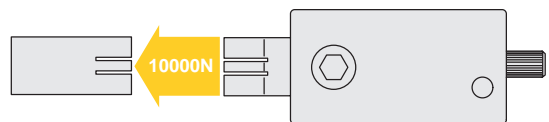



Unique Action - "three finger" Clamping

Our horizontal clamps have a unique "three finger" arrangement ensuring components are both pulled down and clamped in the same motion. The face of the clamp is made of three parts or "fingers":

- Two outer flexible fingers ①; for pulling down the component to the work table.
- One solid central finger ②, to provide direct clamping action.

Available in two styles – smooth and serrated face. They can also cater for workpieces with an adverse angle on the clamping face – for example flame cut steel blanks.

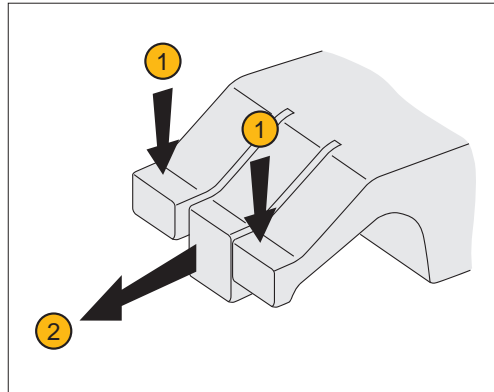

Pull down AND clamp with the highest of clamping forces – from 0,4 tons to 2,2 tons!

Used in our clamping series:

10900, 10940, 10880, 10920, 11040, 11041, 11042, 11043, 11070, 11071, 11080, 11081, 11082, 11083

Clamping Action

The clamps outer flexible fingers ① are approx. 0,25mm longer than the solid central finger/clamping stop ②, this slight difference in length means it is the flexible fingers which first come into contact with the workpiece.

As initial contact is made with the work-piece the flexible fingers ① apply downward pressure forcing the workpiece down against the work table, the flexible fingers are compressed until they are the same length as the solid central finger/clamping stop ②.

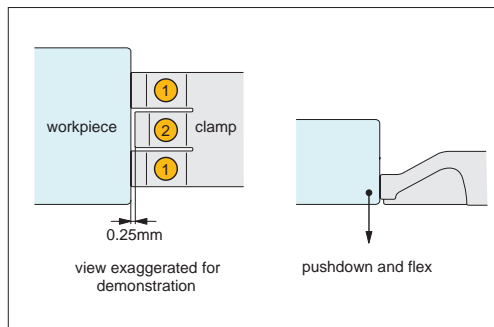

Contact

As the solid central finger/clamping stop ② comes into contact with the work-piece it applies high side clamping pressure to achieve clamping forces up to 2,2 tons (dependent upon clamping model selected).

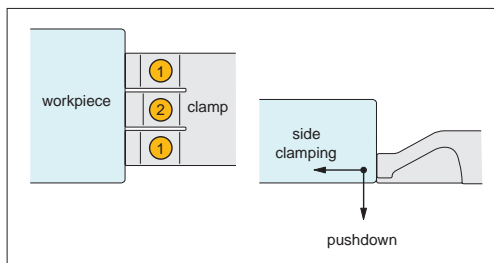

Clamping

During machining the uniquely designed flexible fingers ① continue to flex and twist applying downward pressure to keep the workpiece flat to the work table throughout.

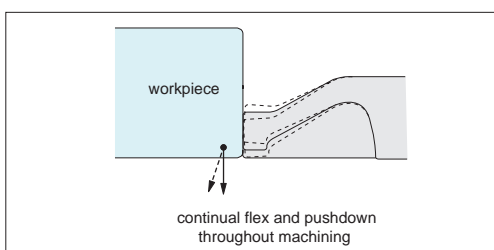

Machining

Precision Positioning

The unique clamping action achieves precision positioning of workpieces – ensuring the workpiece remains parallel to the reference surface.

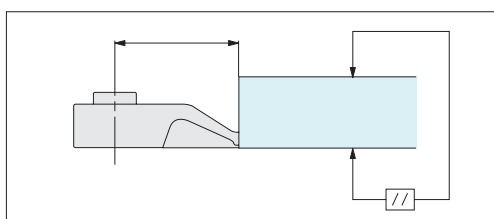



Clamping Torque

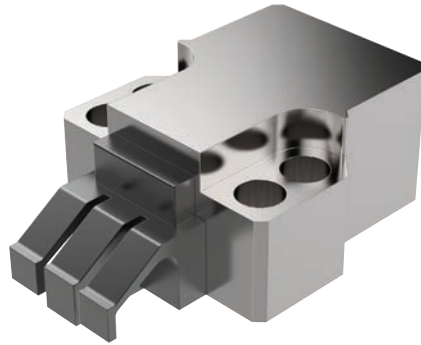

11040/CL2040

Clamping Torque N/m	Clamping Force N
50	23000
40	18000
30	12500
25	11500
20	9500

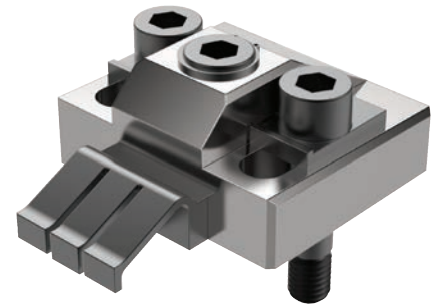

11070/CL2070

Clamping Torque N/m	Clamping Force N
60	16500
50	15000
40	12000
30	10000
25	8000
20	7000

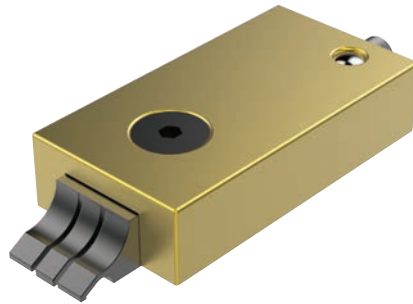

11081/CL2081

Clamping Torque N/m	Clamping Force N
5	6600
4.5	5500
4	4900



10940/CL0030

Clamping Torque N/m	Clamping Force N
8.5	4000
8	3800
7	3400
6	3000
5	2500
4	2000



Horizontal Clamping

up to 2.2 tons



Clamping & Height Setting

Unique Action - "three finger" Clamping

Our horizontal clamps have a unique "three finger" arrangement ensuring components are both pulled down and clamped in the same motion. The face of the clamp is made of three parts or "fingers":

- Two outer flexible fingers ①; for pulling down the component to the work table.
- One solid central finger ②, to provide direct clamping action.

Available in two styles – smooth and serrated face. They can also cater for workpieces with an adverse angle on the clamping face – for example flame cut steel blanks.

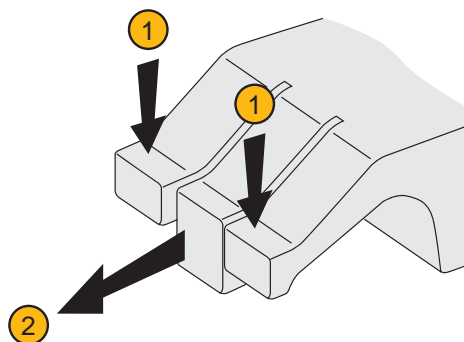

11040/41/42/43

22000N

11070/71

12000N

HEAVY-DUTY SIDE CLAMPING

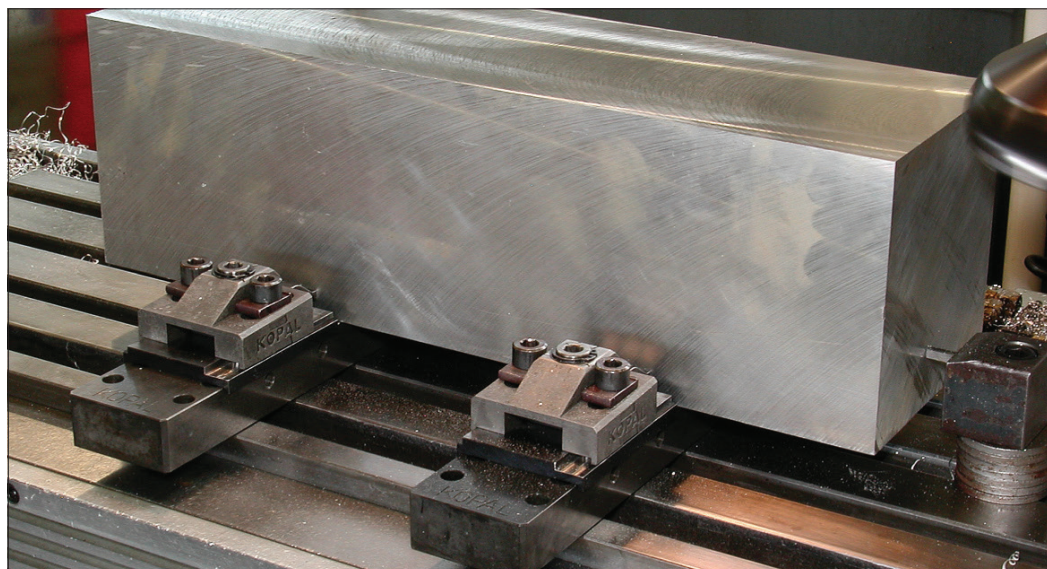

Options

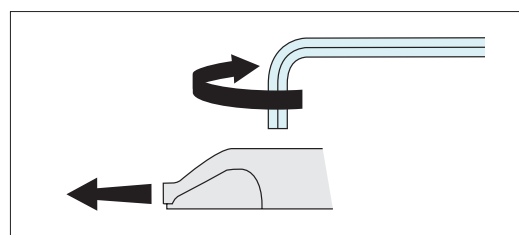

Quick 1/4 turn eccentric clamping – on models offering 4000 and 12000 Newtons clamping force.

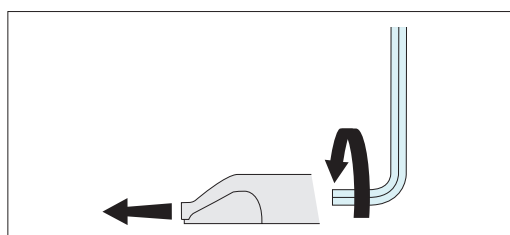

Rear screw clamping – on models offering 6500, 10000 and 22000 Newtons clamping force.

Actuation

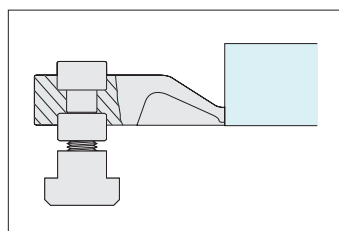

T-Slotted tables

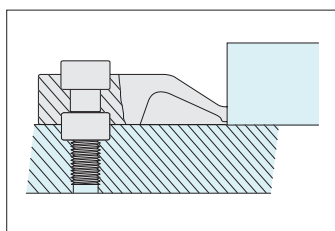

Dedicated fixturing

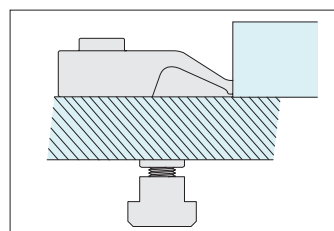

Modular fixturing

Mounting