



# 1.2 Ton Finger Clamps modular vice set

## Heavy-Duty Side Clamping



**11076**

HEAVY-DUTY SIDE CLAMPING

### Material

Steel, hardened, with ground faces.

### Technical Notes

For T-slot tables and fixture plates.

### Tips

Provided with 3 x M12 fixing screws and centring locator.

Order No.	Rail	Stop	Type	Clamp
11076.W0014	2 pc 11045.W0016	1 pc 11071.W0080	Modular Vice Set	1 pc 11070.W0020

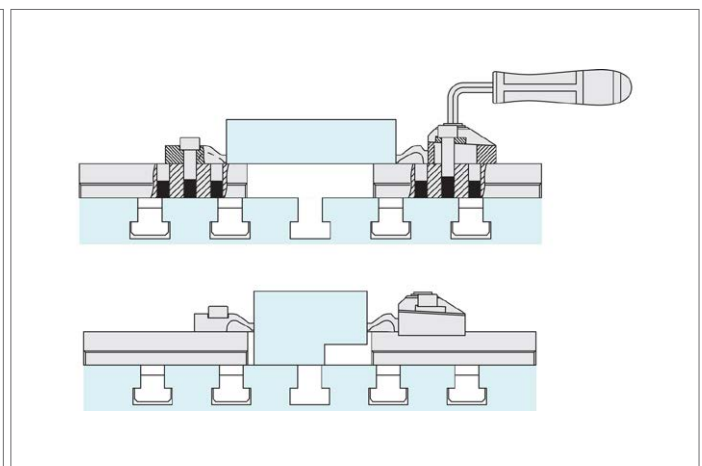
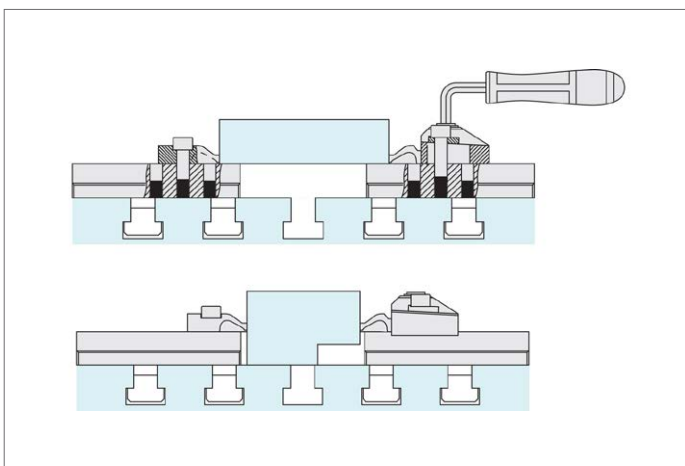



## Application

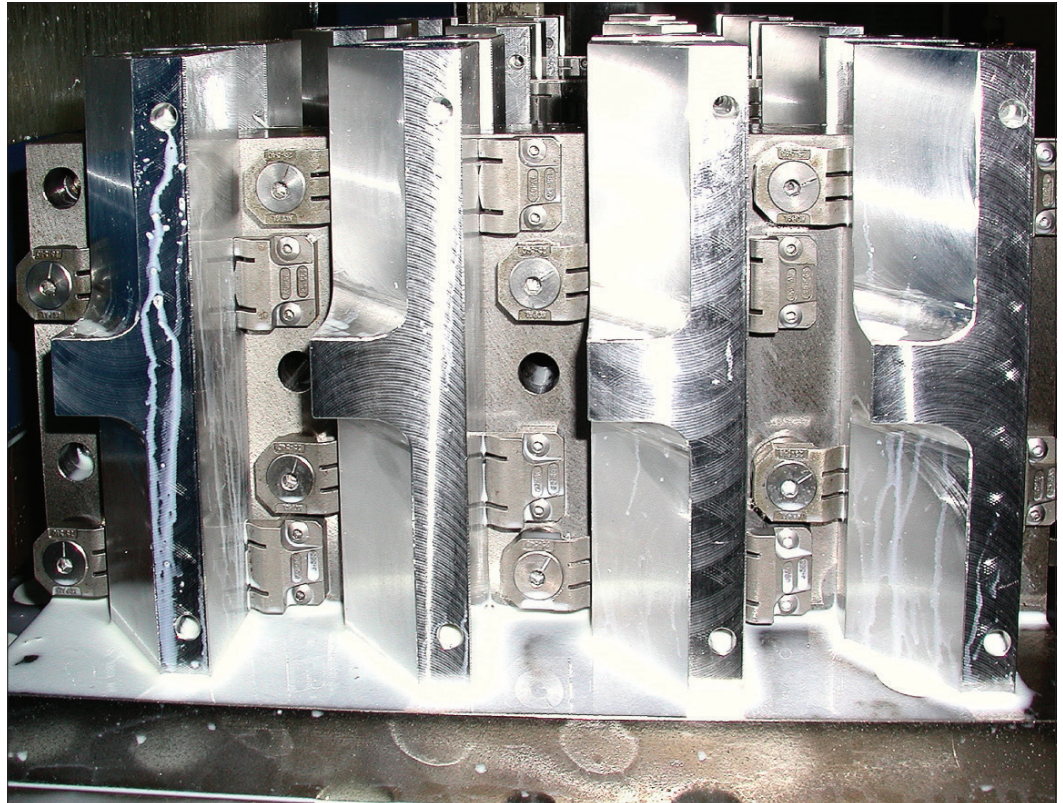

HEAVY-DUTY SIDE CLAMPING

## Unique Horizontal Clamping Set-Ups

**Part No. 10900, 10920, 10940**  
T-slot table and special machining set-ups



**Part No. 11040, 11041, 11042, 11043**  
Supports and special machining set-ups

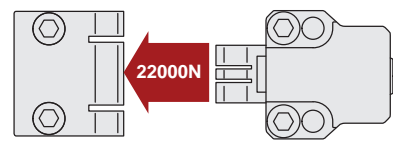

**Part No. 11070, 11071**  
Supports and special machining set-ups

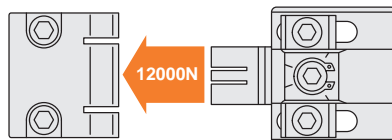

**Part No. 11080, 11081, 11083**  
T-slot table, supports and special machining set-ups

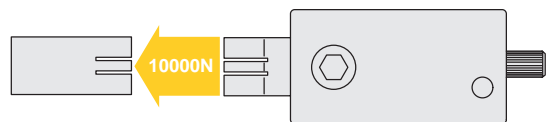



## Unique Action - "three finger" Clamping

Our horizontal clamps have a unique "three finger" arrangement ensuring components are both pulled down and clamped in the same motion. The face of the clamp is made of three parts or "fingers":

- Two outer flexible fingers ①; for pulling down the component to the work table.
- One solid central finger ②, to provide direct clamping action.

Available in two styles – smooth and serrated face. They can also cater for workpieces with an adverse angle on the clamping face – for example flame cut steel blanks.

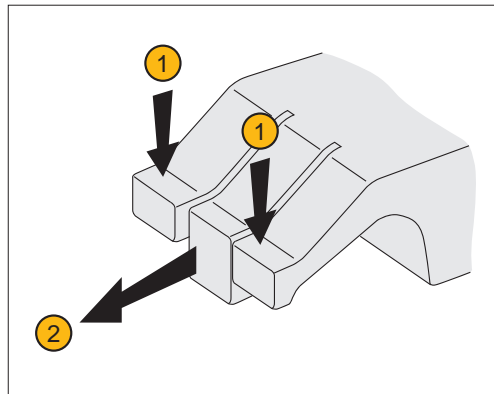

Pull down AND clamp with the highest of clamping forces – from 0,4 tons to 2,2 tons!

Used in our clamping series:

**10900, 10940, 10880, 10920, 11040, 11041, 11042, 11043, 11070, 11071, 11080, 11081, 11082, 11083**

## Clamping Action

The clamps outer flexible fingers ① are approx. 0,25mm longer than the solid central finger/clamping stop ②, this slight difference in length means it is the flexible fingers which first come into contact with the workpiece.

As initial contact is made with the work-piece the flexible fingers ① apply downward pressure forcing the workpiece down against the work table, the flexible fingers are compressed until they are the same length as the solid central finger/clamping stop ②.

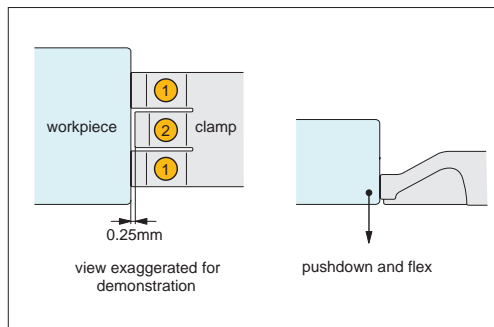

## Contact

As the solid central finger/clamping stop ② comes into contact with the work-piece it applies high side clamping pressure to achieve clamping forces up to 2,2 tons (dependent upon clamping model selected).

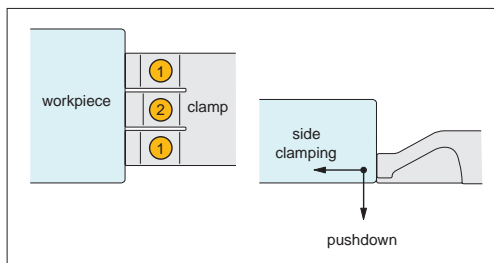

## Clamping

During machining the uniquely designed flexible fingers ① continue to flex and twist applying downward pressure to keep the workpiece flat to the work table throughout.

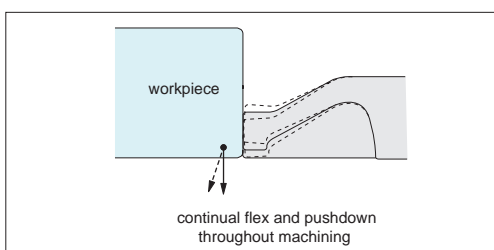

## Machining

## Precision Positioning

The unique clamping action achieves precision positioning of workpieces – ensuring the workpiece remains parallel to the reference surface.

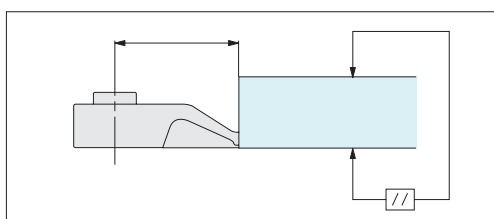



## Clamping Torque

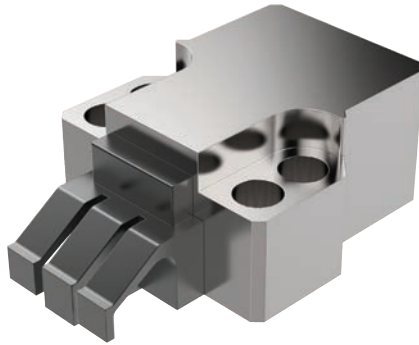

**11040/CL2040**

Clamping Torque N/m	Clamping Force N
50	23000
40	18000
30	12500
25	11500
20	9500

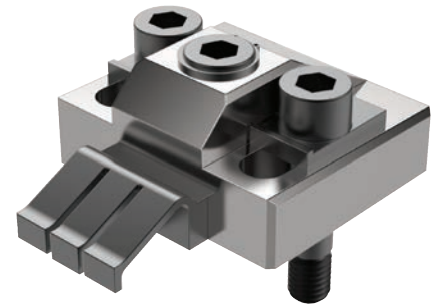

**11070/CL2070**

Clamping Torque N/m	Clamping Force N
60	16500
50	15000
40	12000
30	10000
25	8000
20	7000

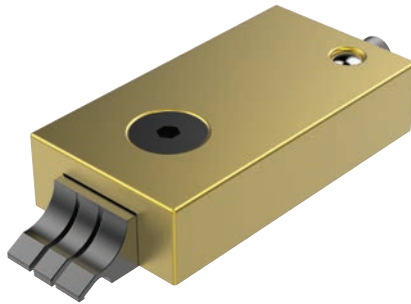

**11081/CL2081**

Clamping Torque N/m	Clamping Force N
5	6600
4.5	5500
4	4900



**10940/CL0030**

Clamping Torque N/m	Clamping Force N
8.5	4000
8	3800
7	3400
6	3000
5	2500
4	2000



# Horizontal Clamping

up to 2.2 tons

# Clamping & Height Setting

## Unique Action - "three finger" Clamping

Our horizontal clamps have a unique "three finger" arrangement ensuring components are both pulled down and clamped in the same motion. The face of the clamp is made of three parts or "fingers":

- Two outer flexible fingers ①; for pulling down the component to the work table.
- One solid central finger ②, to provide direct clamping action.

Available in two styles – smooth and serrated face. They can also cater for workpieces with an adverse angle on the clamping face – for example flame cut steel blanks.

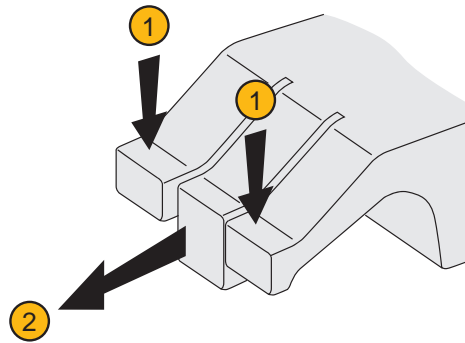

11040/41/42/43

22000N

11070/71

12000N

HEAVY-DUTY SIDE CLAMPING

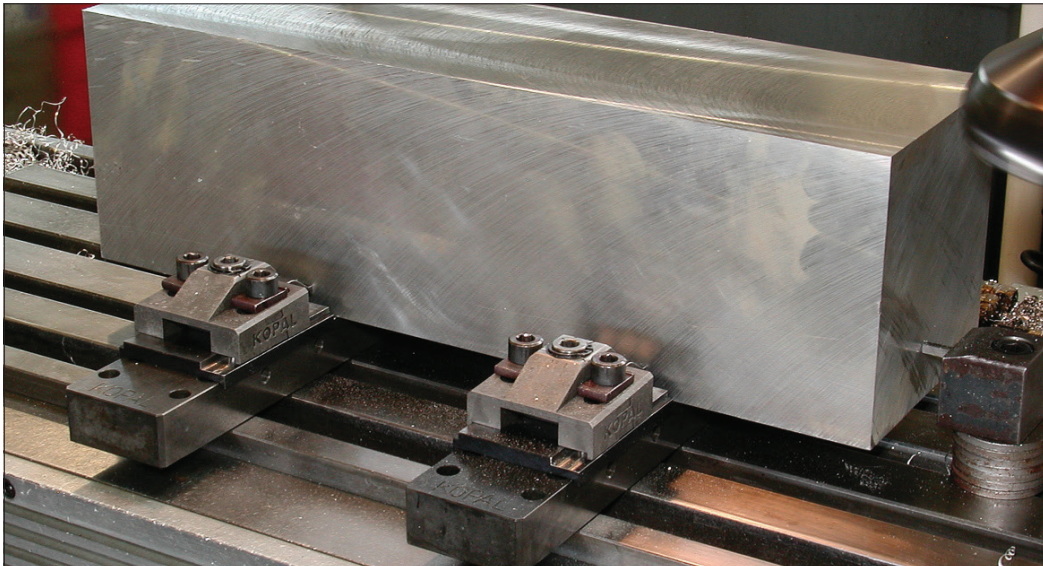

## Options

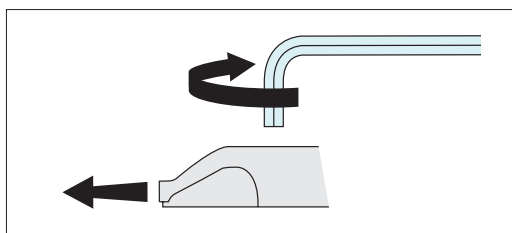

Quick 1/4 turn eccentric clamping – on models offering 4000 and 12000 Newtons clamping force.

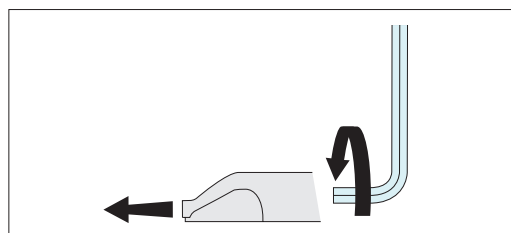

Rear screw clamping – on models offering 6500, 10000 and 22000 Newtons clamping force.

## Actuation

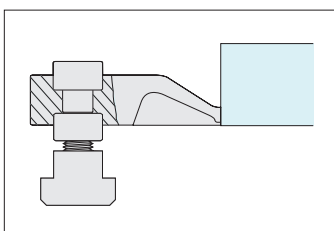

T-Slotted tables

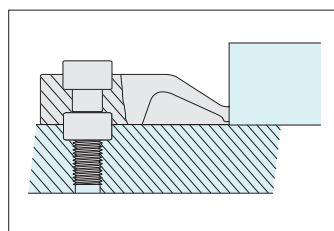

Dedicated fixturing

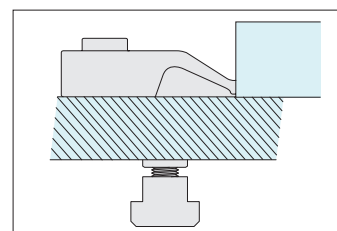

Modular fixturing

## Mounting