

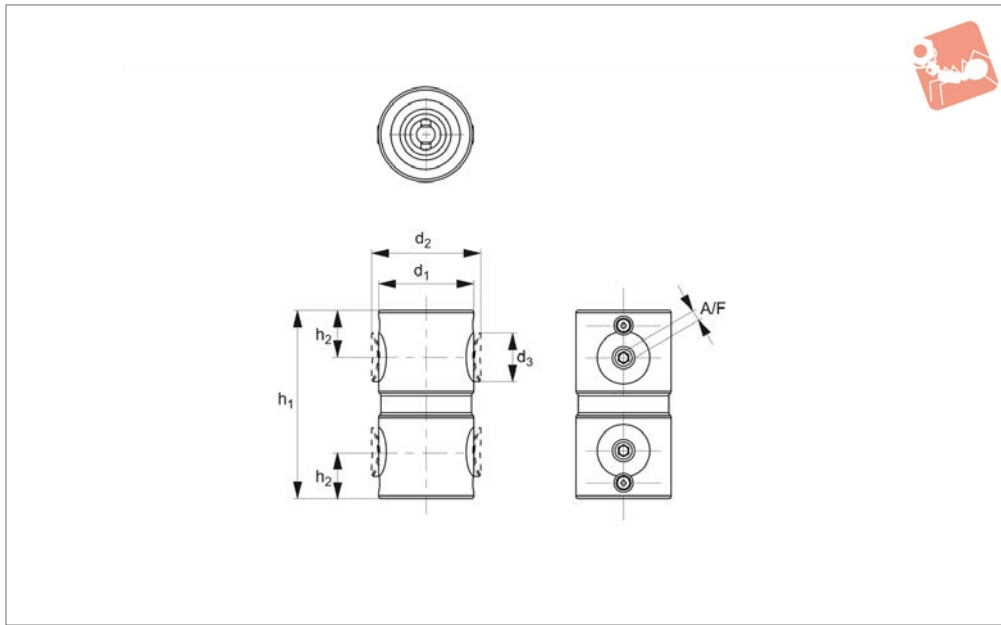

Clamping Module - Double unflanged



Bore Clamping



12044

BORE CLAMPING

Material

Steel (AISI 4140), induction hardened, black oxide finish.

12046 through 12050.

For permissible cutting forces and corresponding workpiece weights when using the clamping module system, see technical pages.

Technical Notes

For suitable clamping screws see part no.s

Order No.	h_1 ± 0.01	h_2	Size	d_1	d_2	d_3	A/F	Clamping force kN max.	Screw torque Nm max.	Weight g
12044.W0008	50	12.5	8	30	34.5	15	3	5	4	200
12044.W0011	80	20.0	11	40	46.0	22	4	8	8	700
12044.W0016	125	30.0	16	60	69.0	32	6	15	22	2600
12044.W0021	160	40.0	21	80	91.0	44	8	25	50	5800