

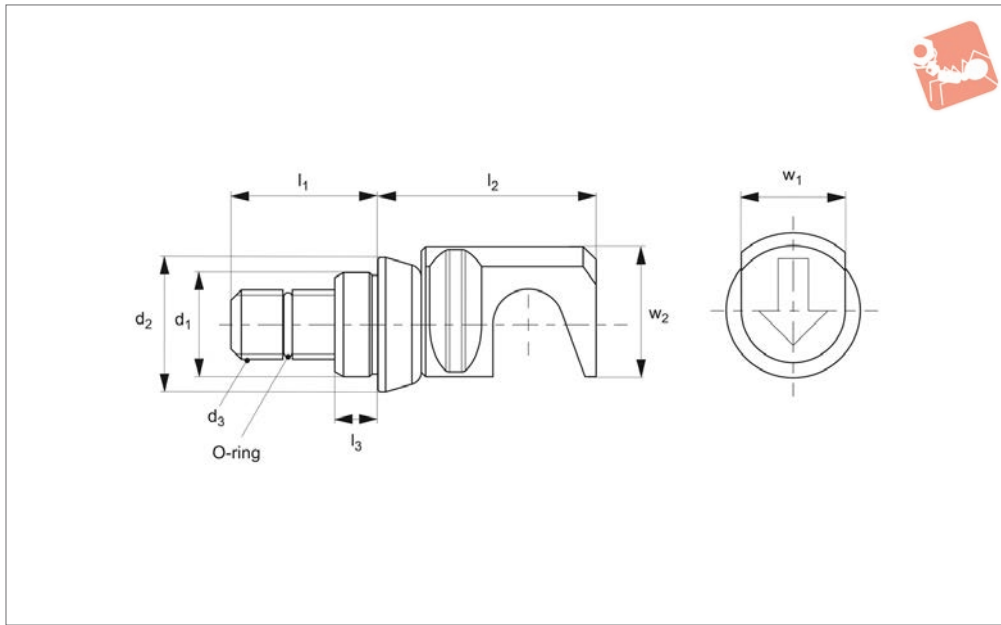

Tapered Clamping Screws - Hook precision

Bore Clamping



12049.3

BORE CLAMPING

Material

Bushing: steel (C45E), black oxide finish, precision ground.
Screw: steel (SCM 435), tempered, black

oxide finish.

O-ring: nitrile rubber.

Technical Notes

For suitable clamping modules see part no. 12049.1.

Order No.	l_1	w_1	Suitable clamping module size	Type	Size	d_1 tol. g6	d_2	O-ring size	d_3	l_2	l_3	w_2	Weight g
12049.W0312	17	12	12	Precision	12	12	15,5	SS050 (CS1 I/D 5,0)	M 8x1,25	25	5,0	15,0	30
12049.W0319	24	19	19	Precision	19	18	24,5	S8 (CS1,5 I/D 7,5)	M12x1,75	40	6,0	23,5	115
12049.W0324	30	24	24	Precision	24	22	31,5	S12 (CS 1,5 I/D 11,5)	M16x2,00	51	7,5	30,0	235