

Manual Actuators for ID Xpansion clamps

Bore Clamping

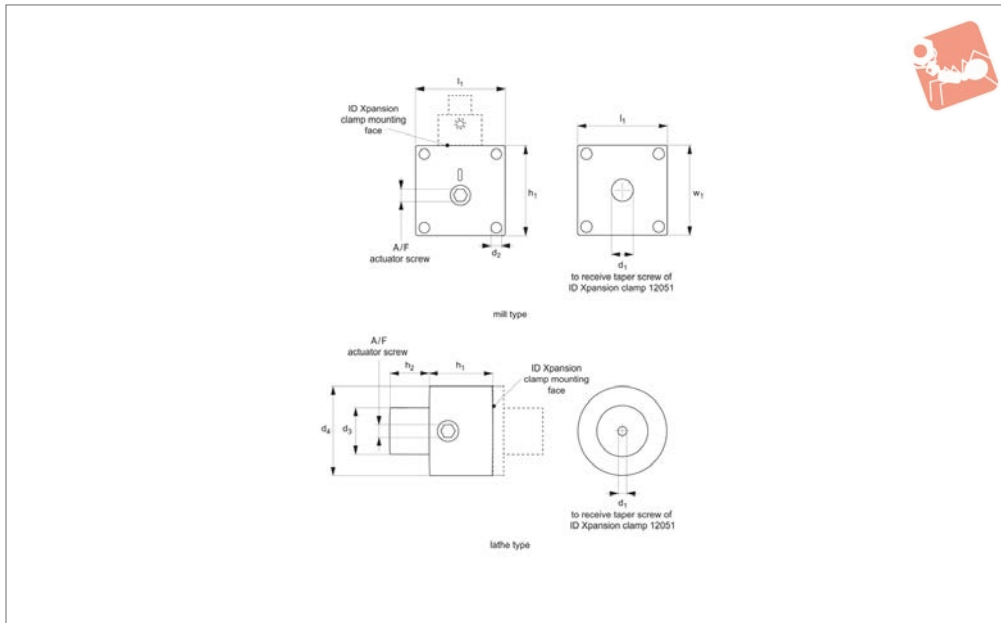

12054

BORE CLAMPING

Material

Steel.

Technical Notes

Versatile manual actuators when combined with our ID Xpansion clamps 12051. Enables clamping of smaller internal diameters and blind holes. Mount corresponding ID Xpansion clamp. Mill type actuator is adaptable and can be used on both vertical and horizontal planes. Once installed the clamp can be actuated with use of an actuator screw (6mm A/F).

Tips

Order ID Xpansion clamp 12051 separately.

Important Notes

Manual actuators for mills and lathes. Introducing another new and innovative workholding system. Specifically designed to clamp on blind internal diameters smaller than our Side-Loc clamps would allow. We took the design a step further, by increasing the functionality to clamp smaller inside diameters. For the mill version the option of holding the workpiece in a

vertical or horizontal plane. By simply mounting our standard ID Xpansion clamps on these manual actuators, or using another style clamp that has a „straight draw“, you can now perform operations that previously required extensive hydraulic/pneumatic cylinders. Mill mounted manual actuators for ID Xpansion clamps are suitable for holding workpieces of very small blind internal diameters.

Order No.	h ₁	h ₂	l ₁	w ₁	Suitable for ID Xpansion clamp	Type	d ₁	d ₂ for	d ₃	d ₄	A/F
12054.W0002	57.2	-	57.2	57.2	.W0010	Mill	M 2	M 6	-	-	6
12054.W0004	57.2	-	57.2	57.2	.W0012	Mill	M 4	M 6	-	-	6
12054.W0006	57.2	-	57.2	57.2	.W0014	Mill	M 6	M 6	-	-	6
12054.W0008	57.2	-	57.2	57.2	.W0020	Mill	M 8	M 6	-	-	6
12054.W0010	57.2	-	57.2	57.2	.W0027	Mill	M10	M 6	-	-	6
12054.W0012	57.2	-	57.2	57.2	.W0035	Mill	M12	M 6	-	-	6
12054.W0102	38	25.4	-	-	.W0010	Lathe	M 2	-	25.0	56.9	6
12054.W0104	38	25.4	-	-	.W0012	Lathe	M 4	-	25.0	56.9	6
12054.W0106	38	25.4	-	-	.W0014	Lathe	M 6	-	25.0	56.9	6
12054.W0108	38	25.4	-	-	.W0020	Lathe	M 8	-	25.0	56.9	6
12054.W0110	38	25.4	-	-	.W0027	Lathe	M10	-	25.0	56.9	6
12054.W0112	38	25.4	-	-	.W0035	Lathe	M12	-	25.0	56.9	6
12054.W0550	-	-	-	-	-	Spare - Actuator Screw	-	-	-	-	-



BORE CLAMPING

