

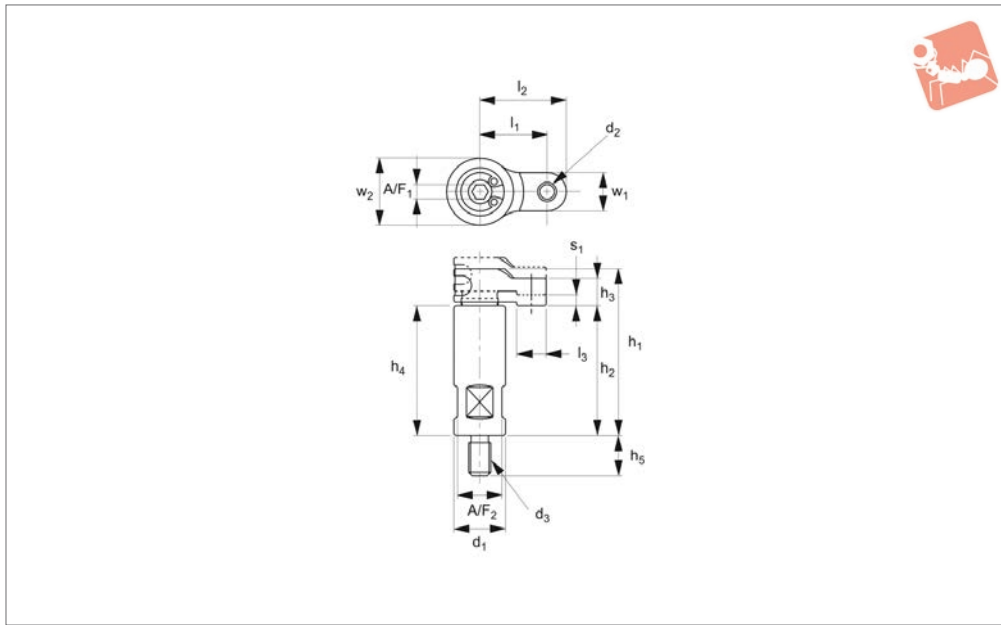

Hook Clamp with holder

Adjustable Vertical Clamps



12550.2

ADJUSTABLE VERTICAL CLAMPS

Material

Clamp body: steel (42CrMo), tempered, black oxide finish.

Holder: steel (C45), tempered, black oxide

finish.

Technical Notes

The hook clamp is designed to move up and

down in conjunction with the tightening screw.

Order No.	h_1	Stroke s_1	l_1	d_1	d_2	h_2	h_3	h_4	h_5	d_3	w_1	w_2	A/F_1	A/F_2	Clamping force kN	Torque Nm max.	Weight g
12550.W0110	45	3	14	14	M 4x0,7	35	7,5	35	11	M 6x1	8	14	3	12	2,0	2,7	55
12550.W0112	53	4	17	16	M 5x0,8	40	9,5	40	14	M 8x1,25	10	16	5	13	3,5	7,0	90

