

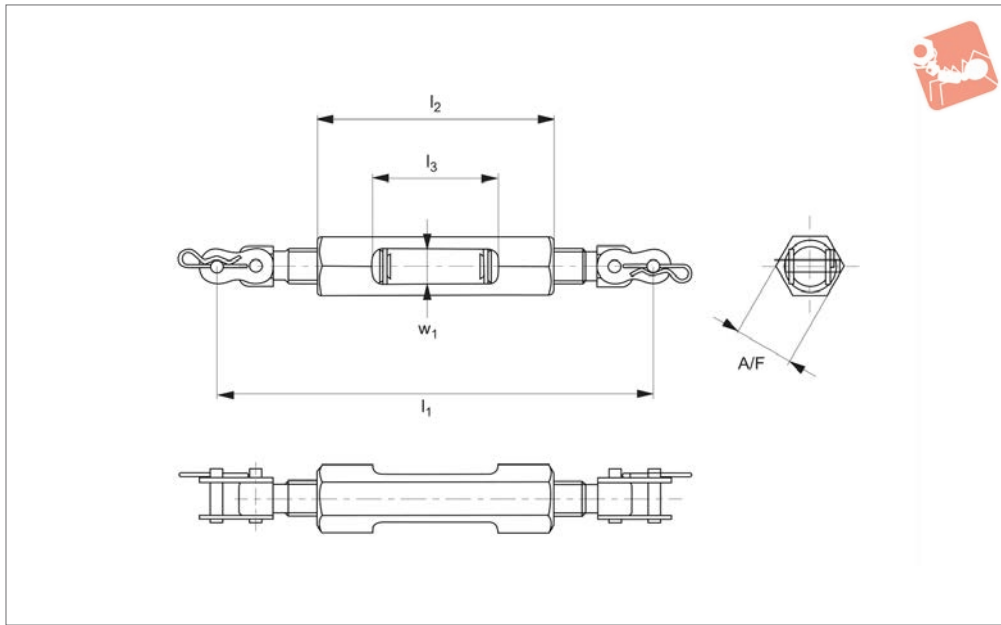

# Turnbuckle for chain clamping set 12700

# Chain Clamping



**12704**

CHAIN CLAMPING

### Material

Alloy steel.

### Technical Notes

For use with chain clamp set 12700. The

turnbuckle is clamped between the chains using two locking links. The chain is pre-tensioned by turning, and the play (caused by lengthening of the chain) is removed.

Order No.	Size	$l_1$	$l_2$	$l_3$	$w_1$	A/F	Clamping force kN max.	Weight g
12704.W0012	12	111-147	97	52	14	24	15	240
12704.W0016	16	151-203	126	66	20	30	40	720
12704.W0020	20	206-270	180	100	31	50	75	2222
12704.W0024	24	214-284	180	105	31	50	120	3517

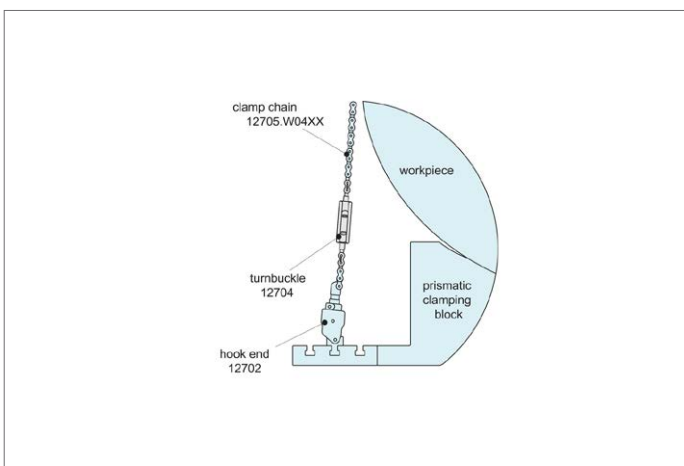



Our comprehensive range of clamping elements includes a compact and powerful workpiece clamping element, the chain clamping set no. 12700. This set was specifically designed for clamping large workpieces with round or arched surfaces.

Due to an increase in the bearing surface of the chain, the clamping force is distributed across the workpiece thereby reducing deformation.

## Setting Up

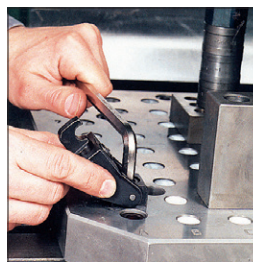

1. Attach the hook unit and the take-up unit as close to the workpiece as possible.



2. Turn the knurled nut on the take-up unit until the pull rod is fully extended. Select the number of chain segments required for the workpiece and attach to the pull rod.



3. Fine adjustment of the chain lengths is made by tightening the knurled nut until the chain slightly touches the workpiece.



4. To clamp the workpiece connect the free end of the chain onto the hook unit. Using a hex key tighten the eccentric shaft, and ensure the lever is rotated to its fully locked position (180°). The workpiece is now clamped.

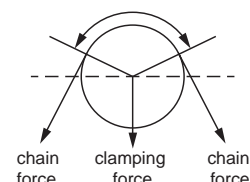

## Important Factors in Selection of Chain Clamp

### Chain Length and Stretch

Torque value of 50 Nm is used for M12 set.

Torque value of 90 Nm is used for M16 set.

The clamping force achievable through the Wixroyd chain clamp set is dependent upon three factors:

- Workpiece diameter (see graph).
- Chain length and stretch (see graph).
- Contact angle of chain and workpiece (see table below right).

Chain Stretch at Specified Torques

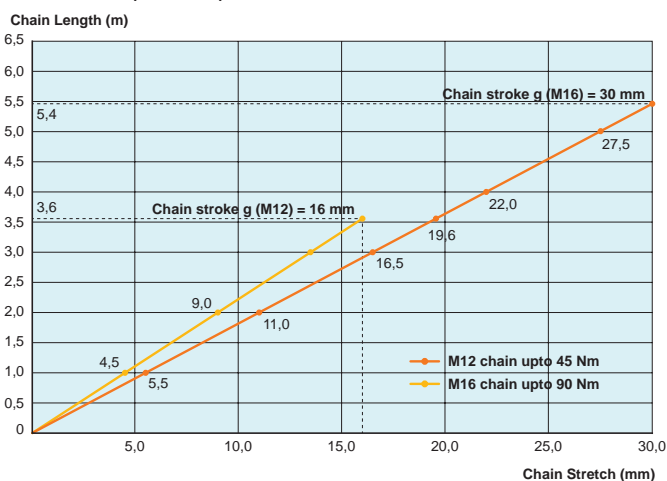

### Table of Clamping Force to Contact Angle $\alpha$

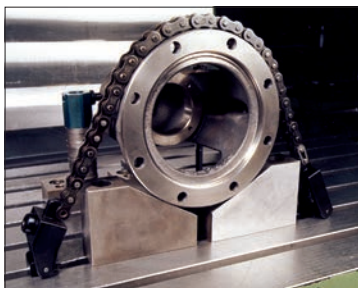

Clamping with the chain clamp set.

Torque	$\alpha = 105^\circ$	$\alpha = 120^\circ$	$\alpha = 135^\circ$	$\alpha = 150^\circ$	$\alpha = 180^\circ$	
M12	50Nm	80%	87%	92%	97%	100%
M16	90Nm	80%	87%	92%	97%	100%

**Important Note:** Achievable clamping force decreases as the contact angle of chain and workpiece ( $\alpha$ ) reduces. Please use the table above as a guide.