

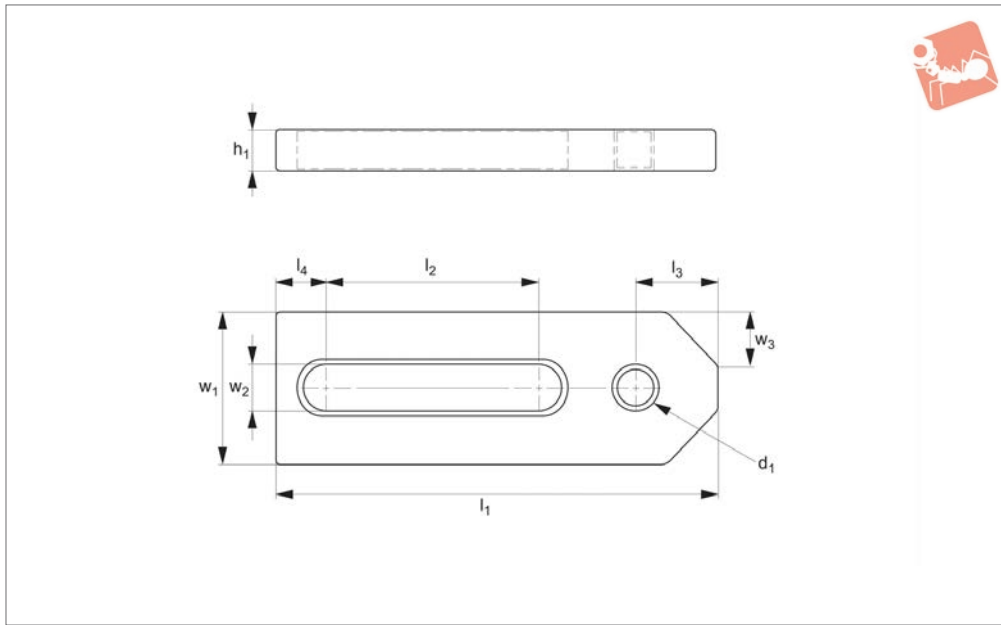

CMM Fixturing Adjustable Stops

M 8 threads

Gauging & Inspection



19326

GAUGING & INSPECTION

Important Notes

Sliding mounting base for easy adjustment and positioning. Thumb screw included.

Order No.	d ₁	h ₁	l ₁	l ₂	l ₃	l ₄	w ₁	w ₂	w ₃ 45° ±0.2	Weight g
19326.W0050	M 8	6.4	51	22	5.0	8	15	8.75	5.0	96
19326.W0075	M 8	6.4	76	45	6.4	8	25	8.75	6.4	150



Wixroyd's CMM fixturing system is designed for easy assembly and high repeatability, eliminating the need to build dedicated fixtures. The system offers a highly accurate and flexible solution of holding parts while probing on CMMs.

Flexible

A variety of component parts as well as complete kits are available; to enable setup of fixtures in minutes.

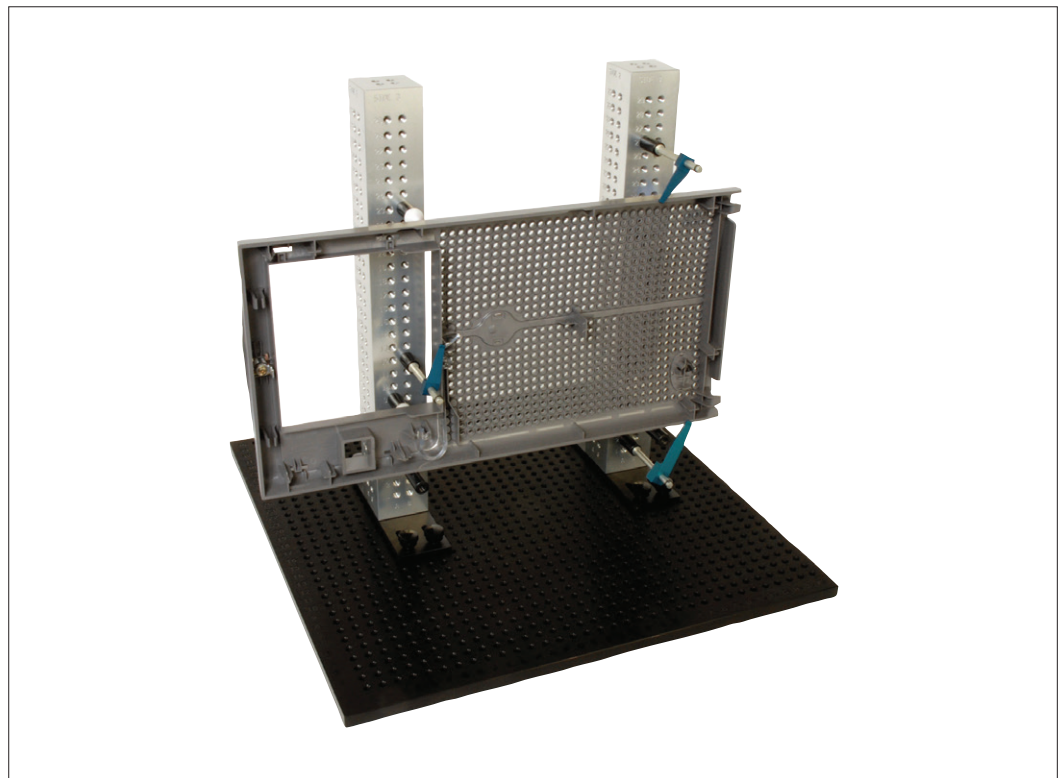
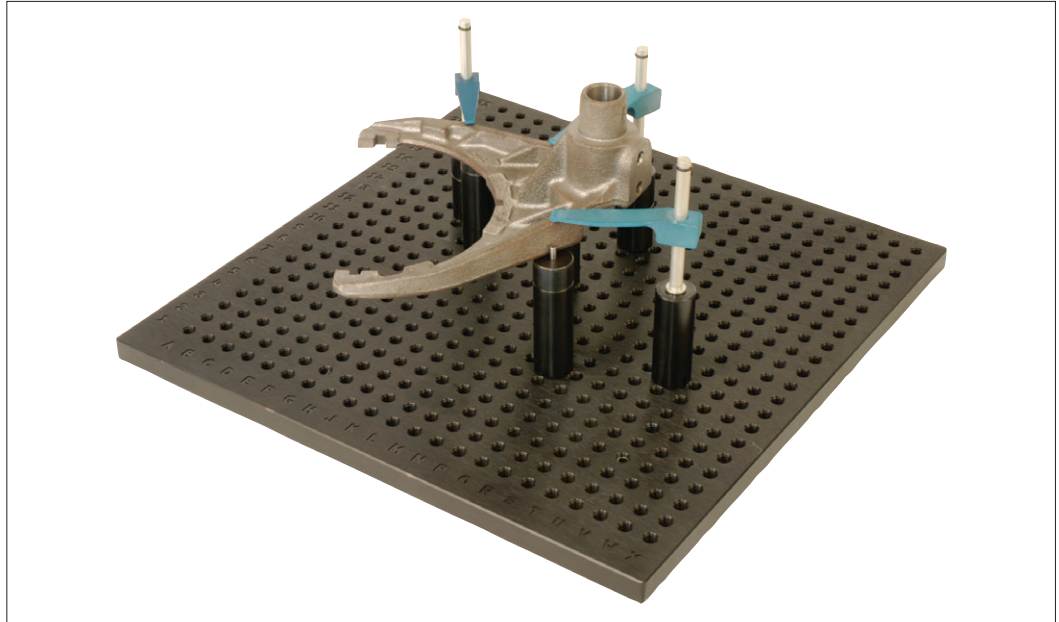

- Aluminium base plates – hole based system with alpha-numeric labelling for easy set-up and recording of fixture positions.
- Fixture towers – ideal for fixturing of large vertical components.
- Soft-touch clamps – non-marking clamps providing the ideal force for holding parts during CMM probing.
- Locating components – rest pads, vee pads for cylindrical parts, pin rests etc.