

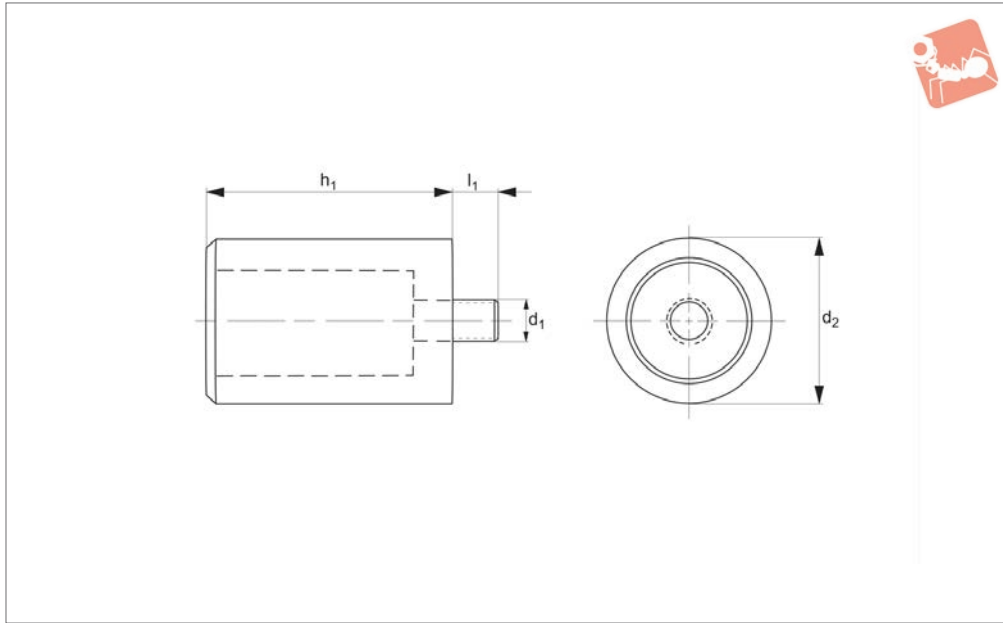

CMM Fixturing Magnetic Rest Buttons

M 8 threads

Gauging & Inspection



19336

GAUGING & INSPECTION

Material

AL NICO magnet in brass sleeve.

Important Notes

For fixturing steel or iron parts. Magnetic force holds parts during probing.

Order No.	d ₁	d ₂	h ₁	l ₁	Weight g
19336.W1325	M 8	12.7	25	8	91
19336.W1925	M 8	19.0	25	8	227
19336.W2525	M 8	25.4	25	8	273



Wixroyd's CMM fixturing system is designed for easy assembly and high repeatability, eliminating the need to build dedicated fixtures. The system offers a highly accurate and flexible solution of holding parts while probing on CMMs.

Flexible

A variety of component parts as well as complete kits are available; to enable setup of fixtures in minutes.

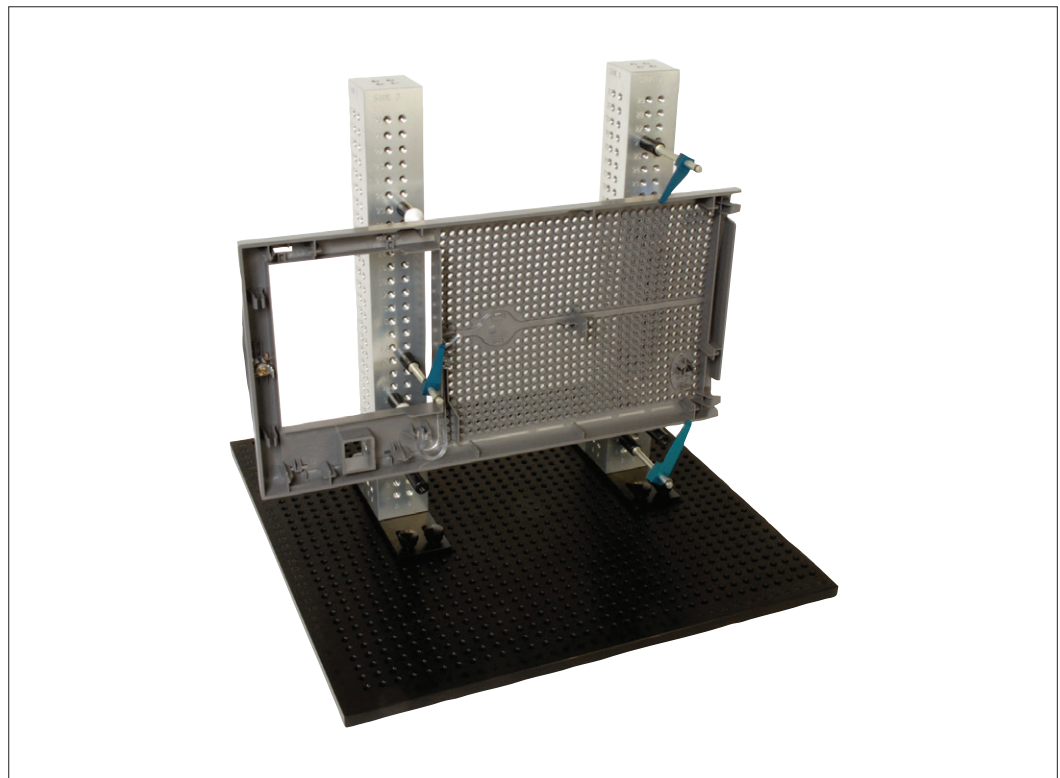
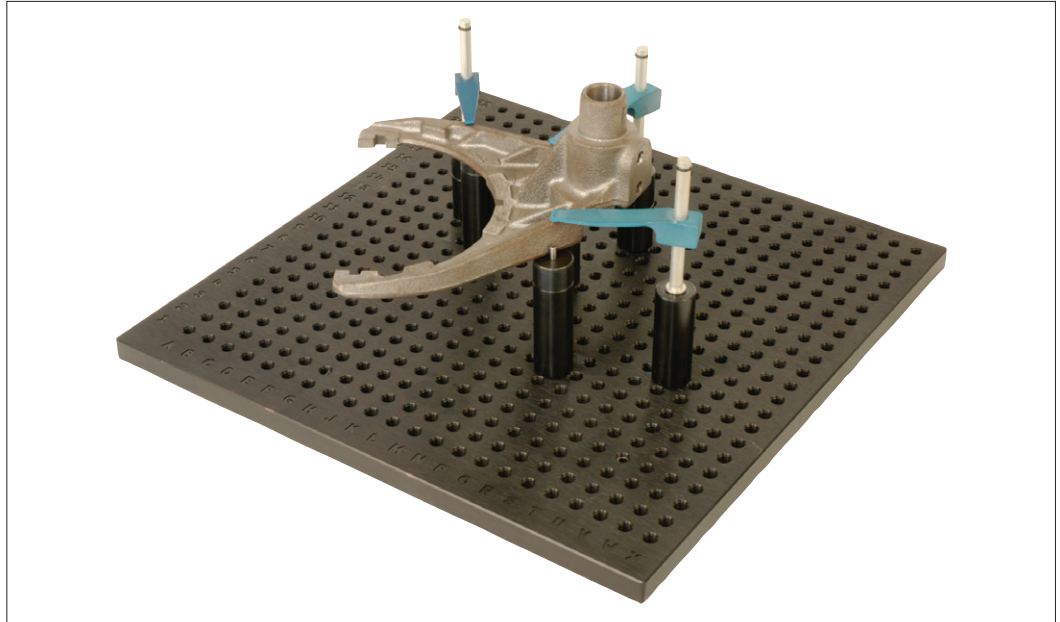

- Aluminium base plates – hole based system with alpha-numeric labelling for easy set-up and recording of fixture positions.
- Fixture towers – ideal for fixturing of large vertical components.
- Soft-touch clamps – non-marking clamps providing the ideal force for holding parts during CMM probing.
- Locating components – rest pads, vee pads for cylindrical parts, pin rests etc.