

CMM Swivel Joint

M 8 threads

Gauging & Inspection

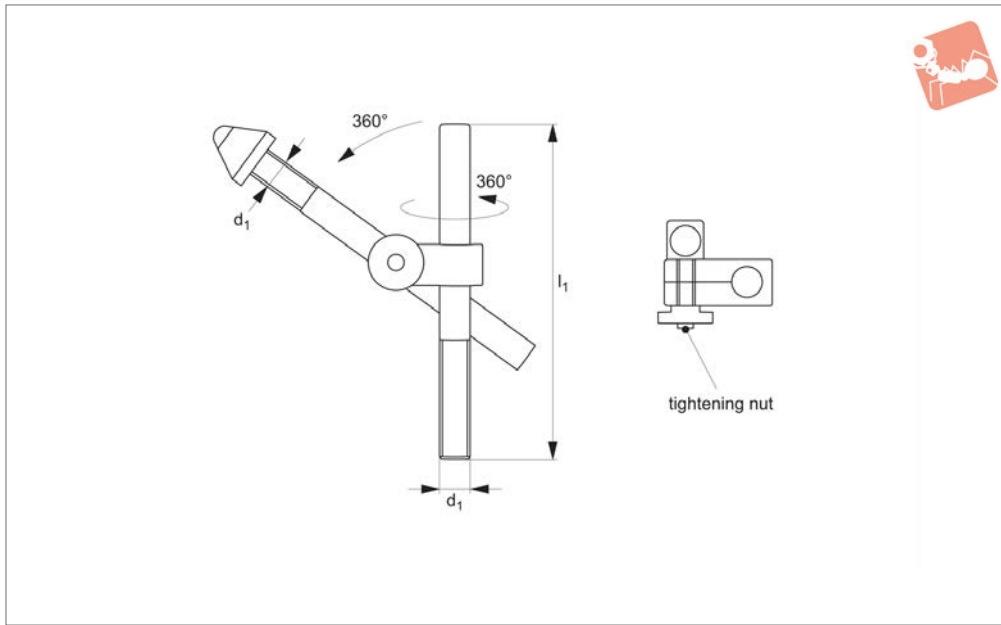

19358

GAUGING & INSPECTION

Technical Notes

Fully articulated adjustable stop, rotates in 360° in both horizontal, vertical plains. Fully XYZ adjustable.

Important Notes

Rotates from side-to-side and up and down. Arm extends and retracts. Rotating arm features thermoplastic cone for posi-

tioning a part without marring its surface.

Order No.	d ₁	l ₁	Weight g
19358.W0008	M 8	100	134



Wixroyd's CMM fixturing system is designed for easy assembly and high repeatability, eliminating the need to build dedicated fixtures. The system offers a highly accurate and flexible solution of holding parts while probing on CMMs.

Flexible

A variety of component parts as well as complete kits are available; to enable setup of fixtures in minutes.

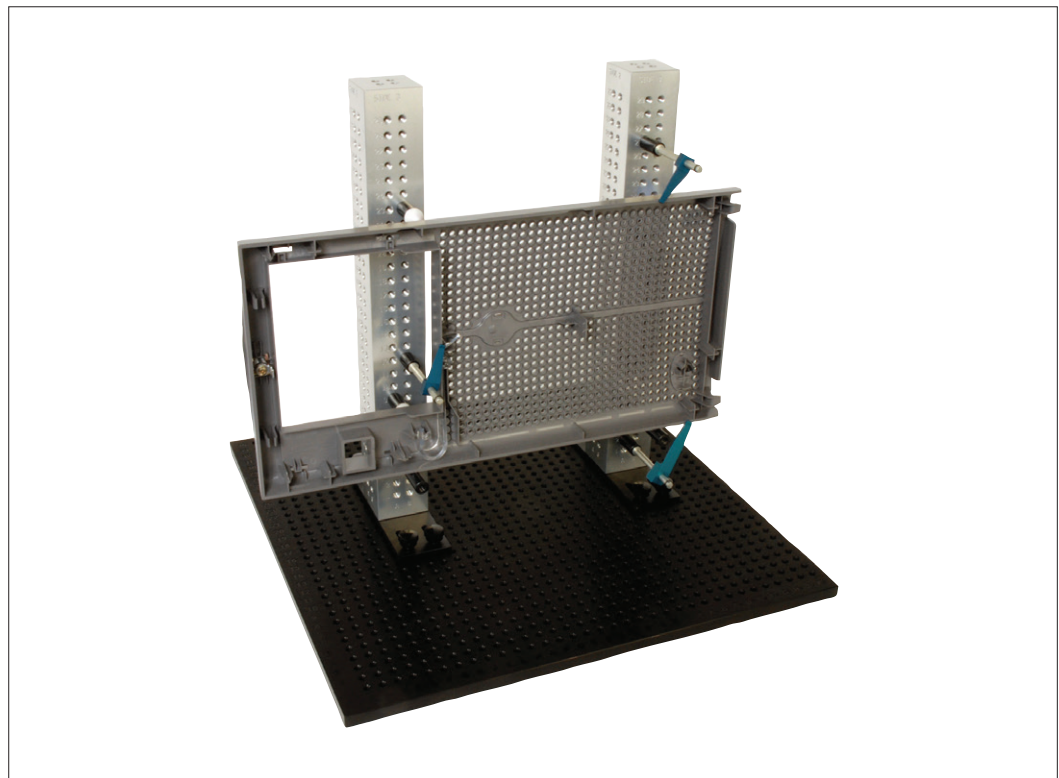
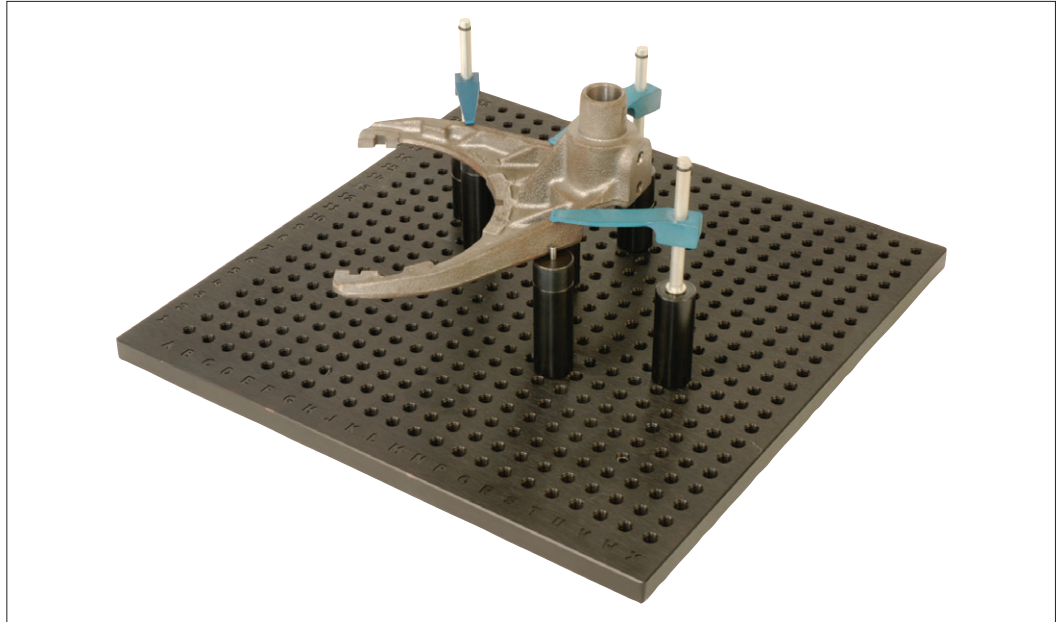

- Aluminium base plates – hole based system with alpha-numeric labelling for easy set-up and recording of fixture positions.
- Fixture towers – ideal for fixturing of large vertical components.
- Soft-touch clamps – non-marking clamps providing the ideal force for holding parts during CMM probing.
- Locating components – rest pads, vee pads for cylindrical parts, pin rests etc.