

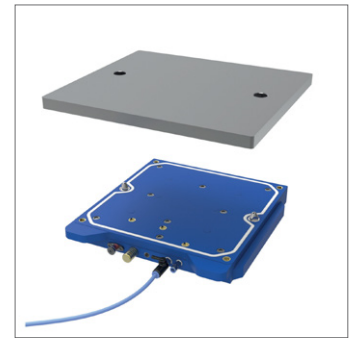

Vacmagic VM300 Vacuum System for vacuum and quick fixture change

Vacuum Clamping Systems

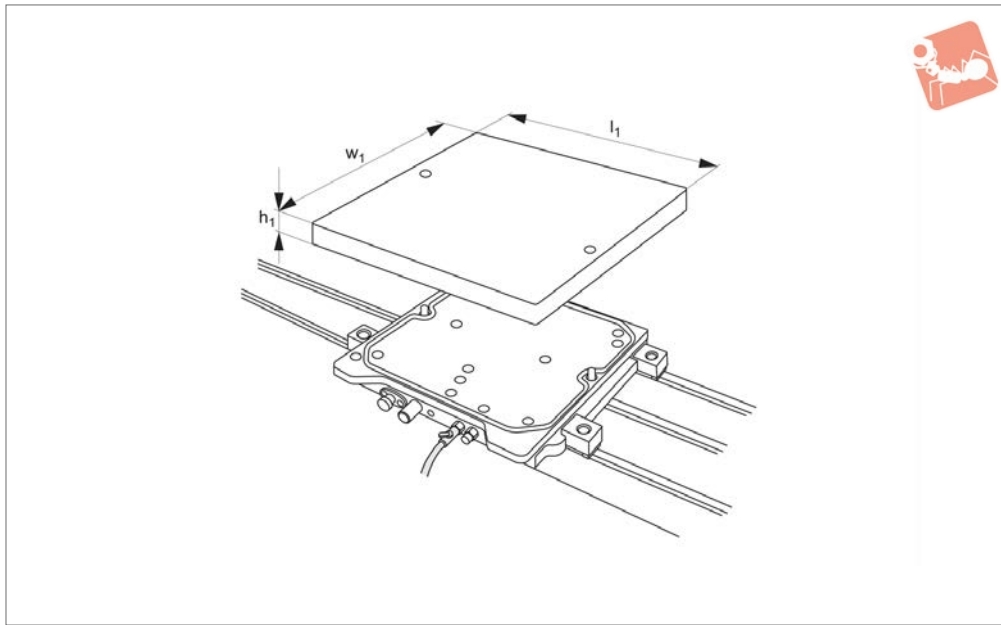

19730

VACUUM CLAMPING SYSTEMS

Technical Notes

Can be used as a traditional vacuum system and for a rapid fixture change system. For vacuum application use the standard vacuum grid pallet or use with the blank pallets machined to suit custom parts. Alternatively, use as a quick fixture change system. Pallets can be swapped in 30 seconds or

less. Load pallets while machining to maximize productivity. Easy to install and set up. Virtually maintenance free - reliable and easy to use. Flexible pallet design. No pumps - use standard shop air. Air supply requirements 70-100 psi. Low pressure safety switch, vacuum indicator, hardened locator pins all included.

Tips

Vacuum pallet 19730.W0150 is machined with cross slots to receive vacuum sealing gasket and machined with M 6 holes for fixing of stops such as sliding stop 12042.W0200. Spare parts readily available, please see replacement parts page.

Order No.	Description	l_1	h_1	w_1	Weight kg
19730.W0101	Complete System Includes: Base Unit, 2 Blank Pallets, 1 Vacuum Pallet	-	-	-	25.5
19730.W0130	Blank Pallet	360	19	315	
19730.W0131	Blank Pallet (1" thick)	379	25	379	5.0
19730.W0150	Vacuum Pallet with M 6 Threaded Holes	360	16	315	14.5
19730.W0160	Large Vacuum Pallet	859	16	368	12.0
19730.W0175	Base (Receiver) - Includes Safety Switch, Required Hoses	323	35	330	25.8