

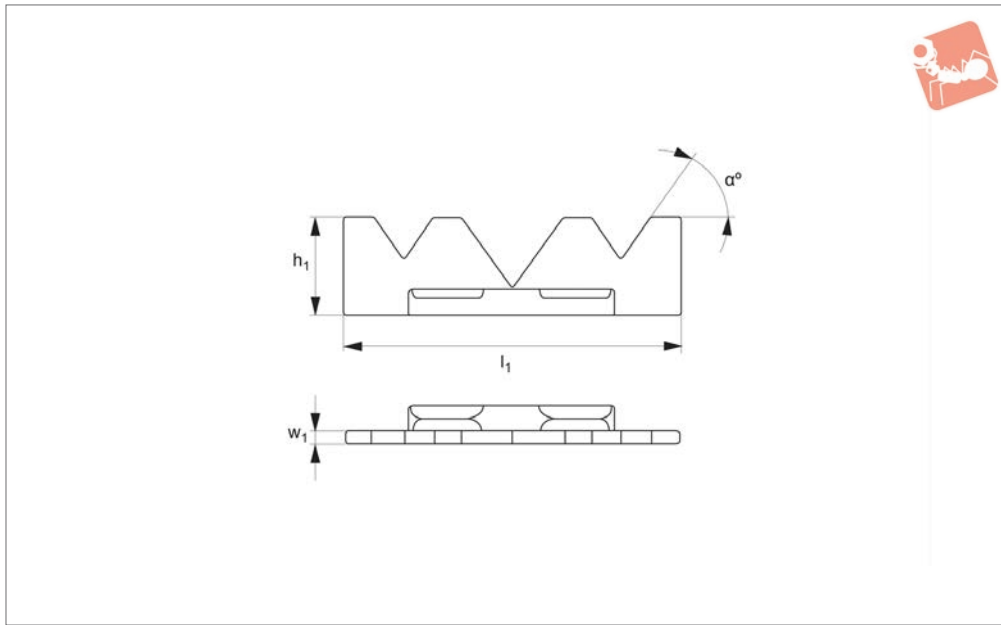

Vice Mill Angles - AccuSnap

for use with AccuSnap master jaws 19810

Vice Clamping



19816

VICE CLAMPING

Material

Body: 80000 psi ductile cast iron.

jaws.

Technical Notes

Use in conjunction with AccuSnap master

Important Notes

All dimensions are in inches.

Order No.	Vice size	Type	l_1	h_1	w_1	α
19816.W0040	4"	Individual	4	1.240	0.118	20
19816.W0041	4"	Individual	4	1.240	0.118	25
19816.W0042	4"	Individual	4	1.240	0.118	30
19816.W0043	4"	Individual	4	1.240	0.118	35
19816.W0044	4"	Individual	4	1.240	0.118	40
19816.W0045	4"	Individual	4	1.240	0.118	45
19816.W0060	6"	Individual	6	1.174	0.118	20
19816.W0061	6"	Individual	6	1.174	0.118	25
19816.W0062	6"	Individual	6	1.174	0.118	30
19816.W0063	6"	Individual	6	1.174	0.118	35
19816.W0064	6"	Individual	6	1.174	0.118	40
19816.W0065	6"	Individual	6	1.174	0.118	45
19816.W0080	8"	Individual	8	2.230	0.118	20
19816.W0081	8"	Individual	8	2.230	0.118	25
19816.W0082	8"	Individual	8	2.230	0.118	30
19816.W0083	8"	Individual	8	2.230	0.118	35
19816.W0084	8"	Individual	8	2.230	0.118	40
19816.W0085	8"	Individual	8	2.230	0.118	45
19816.W0140	4"	Matched Set	4	1.240	0.118	20
19816.W0141	4"	Matched Set	4	1.240	0.118	25
19816.W0142	4"	Matched Set	4	1.240	0.118	30
19816.W0143	4"	Matched Set	4	1.240	0.118	35
19816.W0144	4"	Matched Set	4	1.240	0.118	40
19816.W0145	4"	Matched Set	4	1.240	0.118	45
19816.W0160	6"	Matched Set	6	1.174	0.118	20
19816.W0161	6"	Matched Set	6	1.174	0.118	25
19816.W0162	6"	Matched Set	6	1.174	0.118	30
19816.W0163	6"	Matched Set	6	1.174	0.118	35
19816.W0164	6"	Matched Set	6	1.174	0.118	40
19816.W0165	6"	Matched Set	6	1.174	0.118	45
19816.W0180	8"	Matched Set	8	2.230	0.118	20
19816.W0181	8"	Matched Set	8	2.230	0.118	25
19816.W0182	8"	Matched Set	8	2.230	0.118	30
19816.W0183	8"	Matched Set	8	2.230	0.118	35



Order No.	Vice size	Type	l_1	h_1	w_1	α
19816.W0184	8"	Matched Set	8	2.230	0.118	40
19816.W0185	8"	Matched Set	8	2.230	0.118	45