

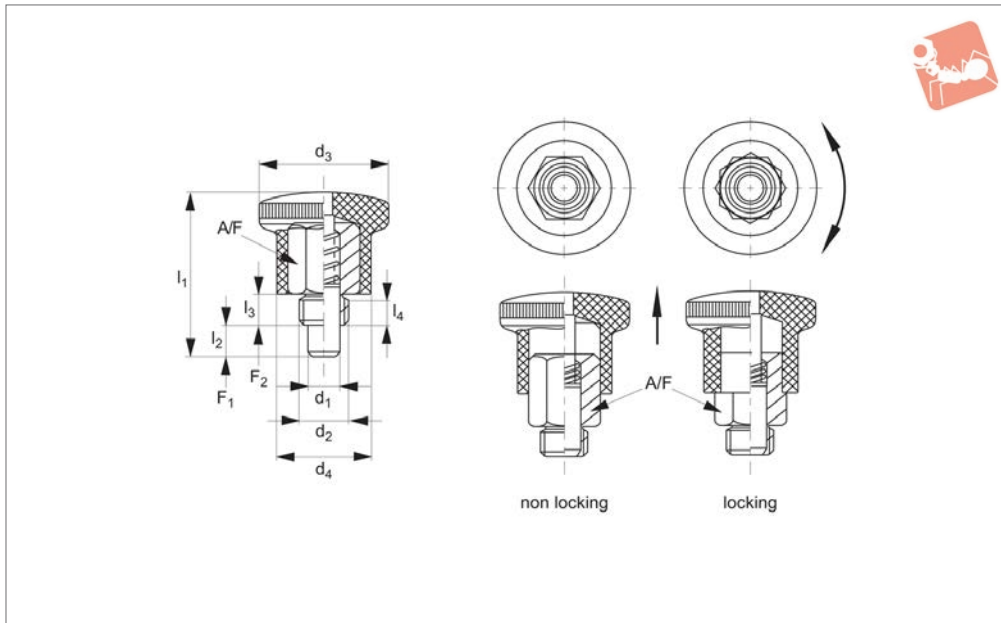

Index Plungers - Pull Grip

mini - for thin walled parts - coarse thread

Index Plunger & Pins



32604

INDEX PLUNGER & PINS

Material

Free cutting steel type-

Body: free cutting steel, galvanized.
Pin: stainless steel 1.4305 (AISI 303).
Grip: thermoplastic PA 6, black.

Stainless steel type-

Body: stainless steel 1.4305 (AISI 303).
Pin: stainless steel 1.4305 (AISI 303).
Grip: thermoplastic PA 6, black.

Technical Notes

„Locking“ type- enable pin to be held in

retracted/non-projecting position; pull back grip, turn 90° to engage „locking“ on a notched catch.

„Non Locking“ type- pin simply springs back when grip released.

For positioning and indexing in the smallest of spaces. Particularly suited for use on sheet metal assemblies; e.g shopfitting displays, electrical cabinets and enclosures etc.

Temperature resistance from -30° to

+80°C.

Distance collars no. 32750 can be used to adapt screw length.

Coarse thread.

Tips

Grip non-removable.

Spring loads * = statistical average

Order No.	Material	Finish	d ₁	d ₂	d ₃	d ₄	l ₁	l ₂	l ₃	A/F	Spring load F ₁ N ≈	Spring load F ₂ N ≈	Weight g
32604.W0602	Steel	Non Locking	4	M 8x1,25	21	15	27.5	5	6	10	4	12	14
32604.W0606	Steel	Non Locking	5	M10x1,50	25	18	34.0	6	8	12	6	16	25
32604.W0610	Steel	Non Locking	6	M10x1,50	25	18	34.0	6	8	12	6	16	25
32604.W0614	Steel	Non Locking	6	M12x1,75	28	20	40.5	7	10	14	10	23	40
32604.W0618	Steel	Non Locking	7	M12x1,75	28	20	40.5	7	10	14	10	23	41
32604.W0622	Steel	Non Locking	8	M16x2,00	33	23	47.5	10	12	17	11	35	66
32604.W0626	Steel	Non Locking	10	M16x2,00	33	23	47.5	10	12	17	11	35	68
32604.W0630	Steel	Locking	4	M 8x1,25	21	15	27.5	5	6	10	4	12	13
32604.W0634	Steel	Locking	5	M10x1,50	23	18	34.0	6	8	12	6	16	23
32604.W0638	Steel	Locking	6	M10x1,50	25	18	34.0	6	8	12	6	16	24
32604.W0642	Steel	Locking	6	M12x1,75	28	20	40.5	7	10	14	10	23	38
32604.W0646	Steel	Locking	7	M12x1,75	28	20	40.5	7	10	14	10	23	39
32604.W0650	Steel	Locking	8	M16x2,00	33	23	47.5	10	12	17	11	35	64
32604.W0654	Steel	Locking	10	M16x2,00	33	23	47.5	10	12	17	11	35	66
32604.W0702	Stainless	Non Locking	4	M 8x1,25	21	15	27.5	5	6	10	4	12	14
32604.W0706	Stainless	Non Locking	5	M10x1,50	25	18	34.0	6	8	12	6	16	25
32604.W0710	Stainless	Non Locking	6	M10x1,50	25	18	34.0	6	8	12	6	16	25
32604.W0714	Stainless	Non Locking	6	M12x1,75	28	20	40.5	7	10	14	10	23	40
32604.W0718	Stainless	Non Locking	7	M12x1,75	28	20	40.5	7	10	14	10	23	41
32604.W0722	Stainless	Non Locking	8	M16x2,00	33	23	47.5	10	12	17	11	35	66
32604.W0726	Stainless	Non Locking	10	M16x2,00	33	23	47.5	10	12	17	11	35	68
32604.W0730	Stainless	Locking	4	M 8x1,25	21	15	27.5	5	6	10	4	12	13
32604.W0734	Stainless	Locking	5	M10x1,50	23	18	34.0	6	8	12	6	16	23
32604.W0738	Stainless	Locking	6	M10x1,50	25	18	34.0	6	8	12	6	16	24



Order No.	Material	Finish	d ₁	d ₂	d ₃	d ₄	l ₁	l ₂	l ₃	A/F	Spring load F ₁ N ≈	Spring load F ₂ N ≈	Weight g
32604.W0742	Stainless	Locking	6	M12x1,75	28	20	40.5	7	10	14	10	23	38
32604.W0746	Stainless	Locking	7	M12x1,75	28	20	40.5	7	10	14	10	23	39
32604.W0750	Stainless	Locking	8	M16x2,00	33	23	47.5	10	12	17	11	35	64
32604.W0754	Stainless	Locking	10	M16x2,00	33	23	47.5	10	12	17	11	35	66



A Wide Selection of Solutions

- Locating and positioning.
- Indexing.
- Securing.
- Positive locking.
- Rapid adjustment of all kinds of tables, platforms and fixtures.
- Machine and fixture design.
- OEM products.
- Sports equipment.
- Medical aides (wheelchairs etc.).
- Aerospace.
- Machine cabinets.

Applications

Materials

Locking or Non Locking

Handling and Actuation Methods

Mounting Options

Additional Technical Notes

Spring Loads



Steel with plastic grip



Stainless with plastic grip



Stainless body and grip



Locking (park)



Non locking (spring back)



Push pull



Standard grip



Lever grip



T-handle



Pull ring

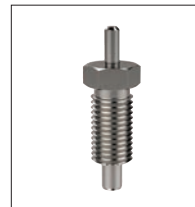

Threaded for bespoke handle



Fine threaded (standard)



Coarse thread



Flange mount



Thin wall mount



Weldable

- Unless otherwise stated, grips on index plungers are not removable.
- Many of the pins on index plungers are toleranced to either the pin or the hole. Please refer to the specific product table.
- Index plungers are not recommended for shear load applications.

	Pin Tol.	Hole Tol.
①	h_9	+0,03 +0,08
②	-0,02 -0,04	H_7

s Stroke, or movement of plunger's pin.

f₁ The force required in Newtons (N) to overcome the static strength of the spring and achieve initial movement of the plunger's pin.

f₂ The force required in Newtons (N) to fully compress the spring until the pin is fully depressed against the plunger's body.

