

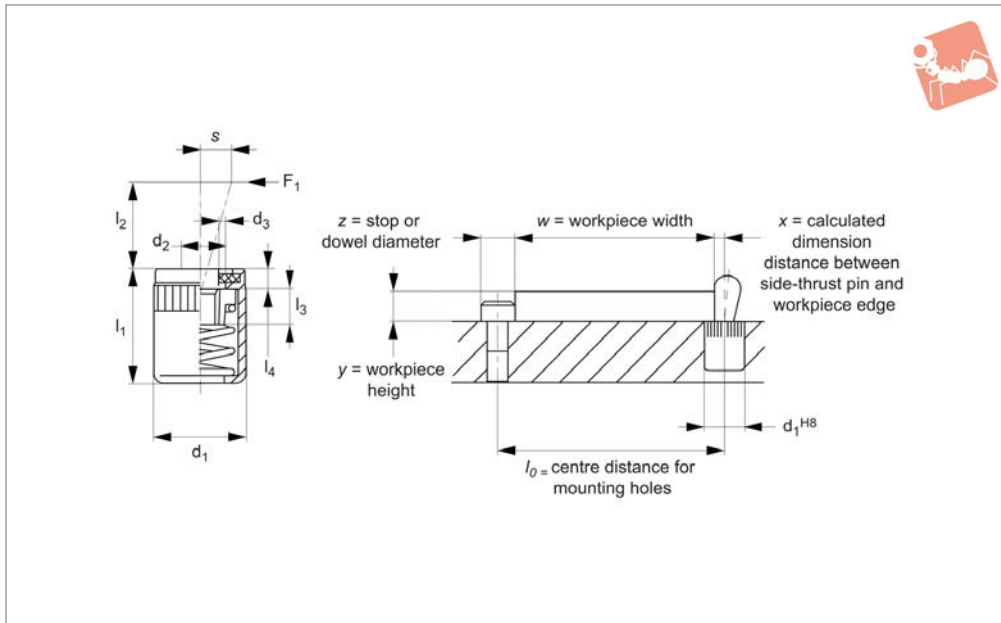

# Side-Thrust Pins - With Seal

for use with pins of your own design

# Spring Plunger & Detent Pins



**32830.2**

SPRING PLUNGER & DETENT PINS

### Material

Body: aluminium.  
 Threaded Washer: steel, blackened.  
 Spring: steel (blackened or blue galvanized), or stainless steel.  
 Seal: rubber (CR), 60 shore.

### Technical Notes

Press fit installation into hole  $d_1$  to tol. H8, using fitting tool (order separately).  
 Installation calculations:  
 A) Calculating centre distance for mounting holes ( $l_0$ ):  
 $l_0 = (z/2) + w + x$

B) Calculating pin location ( $x$ );

When workpiece height ( $y$ ) is greater than or equal to  $l_2 - (d_2/2)$  then ( $x$ ) is calculated as;  
 $x = (d_2/2) - s$

When workpiece height ( $y$ ) is less than  $l_2 - (d_2/2)$  then ( $x$ ) is calculated as;  
 $x = (d_2/2) - s - \{ [l_2 - (d_2/2) - y] * 0.123 \}$

$l_0$  = centre distance for mounting holes  
 $y$  = workpiece height  
 $w$  = workpiece width  
 $x$  = distance between side-thrust pin and

workpiece edge  
 $s$  = stroke  
 $z$  = stop or dowel stop diameter

### Tips

Side-thrust pins are ideal for holding, clamping and positioning parts.  
**Spring colour gives visual indication of spring pressure (N).**  
 Light spring load = natural stainless spring.  
 Standard spring load = steel spring, blackened.  
 Heavy spring load = steel spring, blue galvanized.

Order No.	Spring load	$d_1$	$d_2$	$d_3$	$l_1$ -2	$l_2$	$l_3$	Weight g
32830.W0401	Light	10	M 4	6.3	11	2.5	4.5	2
32830.W0402	Standard	10	M 4	6.3	11	2.5	4.5	2
32830.W0403	Heavy	10	M 4	6.3	11	2.5	4.5	2
32830.W0404	Light	10	M 4	6.3	11	7.5	4.5	2
32830.W0405	Standard	10	M 4	6.3	11	7.5	4.5	2
32830.W0406	Heavy	10	M 4	6.3	11	7.5	4.5	3
32830.W0407	Light	16	M 6	10.3	18	11.5	7.5	9
32830.W0408	Standard	16	M 6	10.3	18	11.5	7.5	9
32830.W0409	Heavy	16	M 6	10.3	18	11.5	7.5	9

Order No.	$l_4$	Location hole $d_1$ tol. H8	Spring colour	Spring pressure N	Stroke s	Temp. resistance °C max.	Fitting tool 32810
32830.W0401	1.8	10	S/S	20	1.6	110	.W0831
32830.W0402	1.8	10	Black	50	1.6	110	.W0831
32830.W0403	1.8	10	Blue	100	1.6	110	.W0831
32830.W0404	1.8	10	S/S	40	2.0	110	.W0831
32830.W0405	1.8	10	Black	75	2.0	110	.W0831
32830.W0406	1.8	10	Blue	100	2.0	110	.W0831
32830.W0407	2.0	16	S/S	100	3.2	110	.W0833
32830.W0408	2.0	16	Black	150	3.2	110	.W0833

# Spring Plunger & Detent Pins

## Side-Thrust Pins - With Seal for use with pins of your own design



Order No.	$l_4$	Location hole $d_1$ tol. H8	Spring colour	Spring pressure N	Stroke s	Temp. resistance °C max.	Fitting tool 32810
32830.W0409	2.0	16	Blue	200	3.2	110	.W0833

SPRING PLUNGER & DETENT PINS

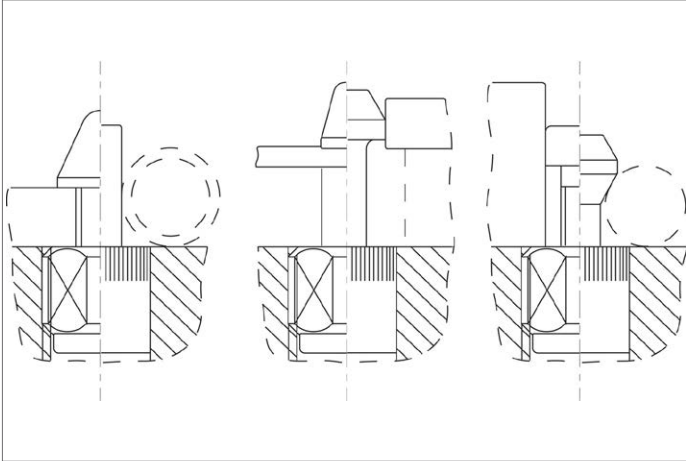



## A Wide Selection of Solutions

- Locating and positioning.
- Indexing.
- Securing.
- Positive locking.
- Rapid adjustment of all kinds of tables, platforms and fixtures.
- Machine and fixture design.
- OEM products.
- Sports equipment.
- Medical aides (wheelchairs etc.).
- Aerospace.
- Machine cabinets.

## Applications

## Materials

## Locking or Non Locking

## Handling and Actuation Methods

## Mounting Options

## Additional Technical Notes

## Spring Loads



Steel with plastic grip



Stainless with plastic grip



Stainless body and grip



Locking (park)



Non locking (spring back)



Push pull



Standard grip



Lever grip



T-handle



Pull ring



Threaded for bespoke handle



Fine threaded (standard)



Coarse thread



Flange mount



Thin wall mount



Weldable

- Unless otherwise stated, grips on index plungers are not removable.
- Many of the pins on index plungers are toleranced to either the pin or the hole. Please refer to the specific product table.
- Index plungers are not recommended for shear load applications.

	Pin Tol.	Hole Tol.
①	$h_9$	+0,03 +0,08
②	-0,02 -0,04	$H_7$

**s** Stroke, or movement of plunger's pin.

**f<sub>1</sub>** The force required in Newtons (N) to overcome the static strength of the spring and achieve initial movement of the plunger's pin.

**f<sub>2</sub>** The force required in Newtons (N) to fully compress the spring until the pin is fully depressed against the plunger's body.

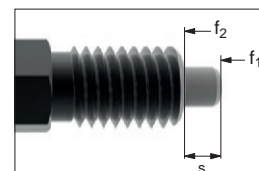



Wixroyd side-thrust pins are an economical way to clamp, hold and position components – from low height PCB's to relatively large castings.



### Easy to Use

Simple to mount, easy to use and space saving.

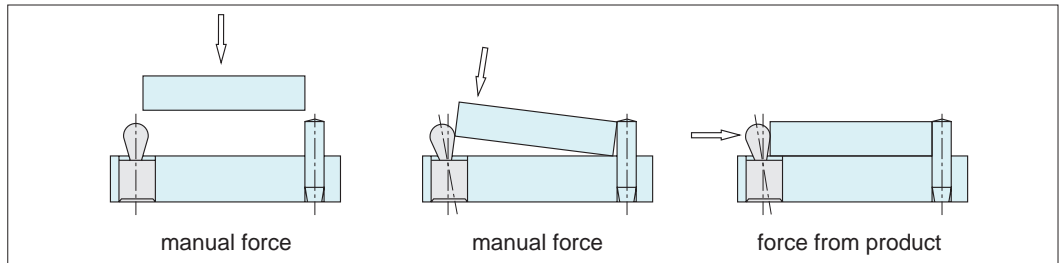

- Easy handling.
- Minimum mounting space.
- Simple and rapid changeover.
- Ideal for flat pieces.
- Reduced clamping times.
- Constant clamping pressure.

## Installation Calculations of Side Thrust Pins

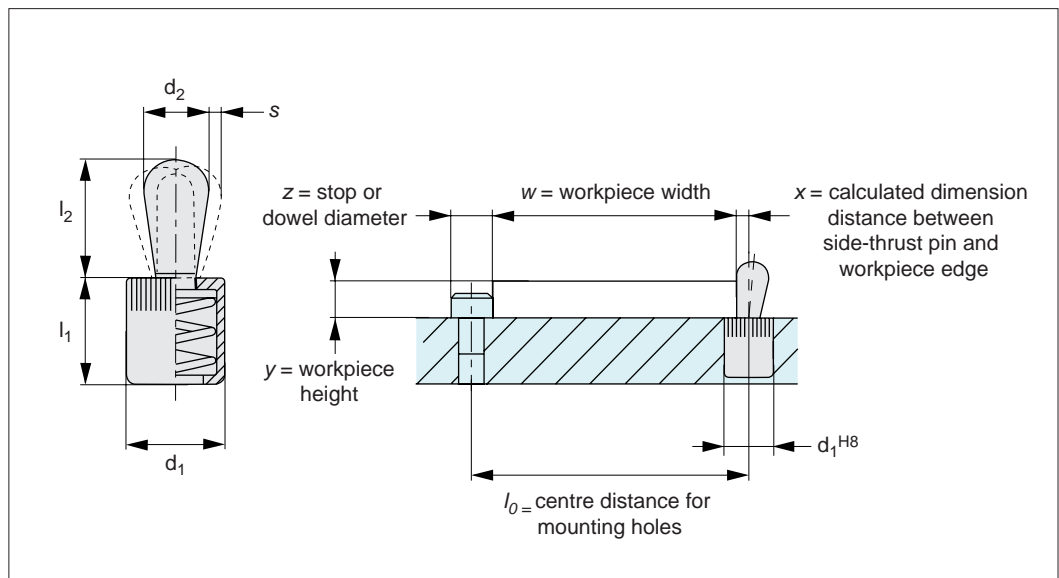

A) Calculating centre distance for mounting holes ( $l_0$ );

$$l_0 = (z/2) + w + x$$

B) Calculating pin location ( $x$ );

When workpiece height ( $y$ ) is greater than or equal to  $l_2 - (d_2/2)$  then ( $x$ ) is calculated as;

$$x = (d_2/2) - s$$

When workpiece height ( $y$ ) is less than  $l_2 - (d_2/2)$  then ( $x$ ) is calculated as;

$$x = (d_2/2) - s - \{ [l_2 - (d_2/2) - y] * 0.123 \}$$

$l_0$  = centre distance for mounting holes

$y$  = workpiece height

$w$  = workpiece width

$x$  = distance between side-thrust pin and workpiece edge

$s$  = stroke

$z$  = stop or dowel stop diameter

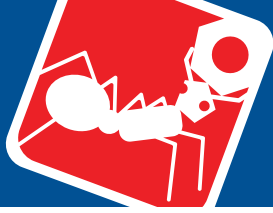

# Wixroyd Side-Thrust Pins

## factors to consider in pin selection

32810 - 32870  
Positioning Elements

The best selection of side thrust pins is made with consideration to the following four factors:

- a) Pin size Ø
- b) Pin material
- c) Sealed or non-sealed pin
- d) Required pin force

Pin size Ø	Application
3 mm	Circuit boards, thin metals
4 mm	Electronics, measuring equipment, small precise parts
5 mm	Drilling jigs, sheet metal, measuring devices, welding fixtures
6 mm	Fixtures for light machine parts and castings
8 mm	Fixtures for medium machine parts and castings
10 mm	Fixtures for heavy machine parts and castings

### Pin Size Ø

Plastic pins for sensitive parts. Steel pins for other parts. Stainless steel pins in corrosive environments.

### Pin Material

With/without seal	Application	Operation
<b>Use side-thrust pins with seal</b> e.g. 32820, 32850 etc	Milling, drilling, reaming, broaching, honing, engraving	Machining
	Washing, polishing, painting, sand blasting	After machining
<b>Use side-thrust pins without seal</b> e.g. 32810, 32840 etc	Gluing, welding, hard soldering	Prior to machining
	Gripping, inserting, fitting	Final mounting
	Measuring, controlling, loading	Quality assurance
	Soft soldering, checking	Processing circuit boards

### Sealed or Non-sealed Pin

Positioning applications 30 - 60 N. Clamping applications 90 - 150 N.

### Pinforce - Guide Only

Available in an aluminium body, and in various spring pressures from 10 to 300N. Each pin size is usually available in 3 spring pressures.

Pressure	Low	Medium	High
Spring Colour	Stainless	Black	Blue

### Compression Spring Type

Available in elastomer body and in various spring pressures from 10 to 160N.

### Elastomer Spring Type

Side-thrust pins find applications in the following industries and more:

- Automotive.
- Aviation.
- Electronics.
- Computing.
- Plastics.
- Medical.
- Precision engineering.
- Tool manufacturing.

### Typical Applications

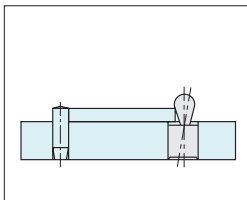

Positioning and clamping even extremely flat parts (e.g. metal sheets and printed circuit boards).

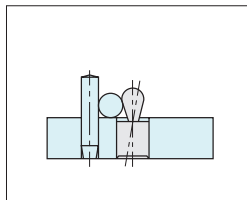

Positioning and clamping round metal using the deep drawing effect.

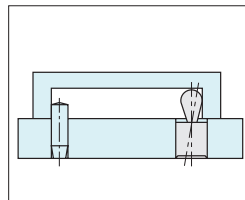

Space saving positioning and clamping from the inside to the outside.

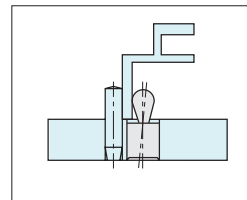

Positioning and clamping different profiles when welding. Material expansions compensated for by flexibility of the side-thrust pin.