

## 35490

GRIPPERS & REST PADS

### Material

M2 tungsten-molybdenum high-speed steel, hardened to HRC 60-62.

### Technical Notes

These hardened steel gripping pads press down onto the surface of the clamped

workpiece for safe holding without distortion. They are especially suitable where a high load or clamping force is applied. They can be built into clamps, stops and fixtures as well as chucks, vices and robotic grippers for extra grip.

### Tips

Can be fastened from the front using a socket head cap screw.

Note installation recommendations in technical diagram.

Order No.	Tooth pattern	$l_1$ +0.00 -0.13	$d_1$ to fit DIN 912	$h_1$ +0.00 -0.13	$h_2$	$w_1$
35490.W0001	Fine	12	M 4	10	5.6	3,2x90°
35490.W0002	Fine	12	M 4	12	5.6	3,2x90°
35490.W0003	Fine	20	M 5	10	6.6	3,2x90°
35490.W0004	Fine	20	M 5	12	6.6	3,2x90°
35490.W0005	Fine	25	M 6	10	7.6	3,2x90°
35490.W0006	Fine	25	M 6	12	7.6	3,2x90°
35490.W0161	Fine	16	M 4	10	5.6	3,2x90°
35490.W0162	Fine	16	M 4	12	5.6	3,2x90°



Grippers enhance workholding for multiple machining operations.

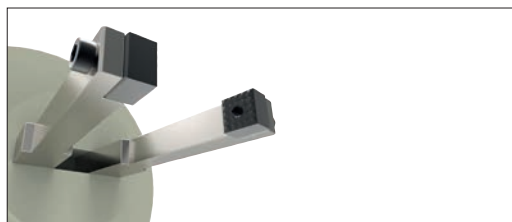

Grippers increase handling capability.

## Pads and Gripper Options

### Pads

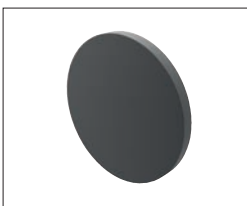

**Solid Carbide**

High impact carbide pads, can be brazed or bonded into place.



**Carbide Tipped**

Constructed with high impact carbide pad brazed to a heat treated alloy steel body. Mount via tapped hole or a flat on the outside diameter for set screw mounting.



**Hardened Steel**

Made from 8620 steel, carburized and hardened to Rc 58/60 1.2mm with black oxide finish. Mount via tapped or counter bored hole.



**Non-marking Thermoplast**

Made from white thermoplast. Mount via tapped or counter bored hole.



**Stainless Steel**

Pad from 17-4 stainless steel, hardened to Rc 43/46. Mount via tapped or counter bored hole.

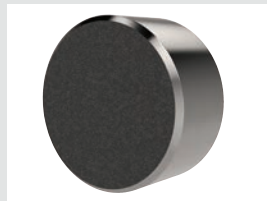

**Abrasive Diamond Surface**

Abrasive surface permanently fused to a 17-4 stainless steel pad, hardened to Rc 43/46. The surface texture is comparable to a 100 grit abrasive. Mount via tapped or counter bored hole.



**Soft Urethane Surface**

Urethane surface is permanently bonded to a 300 series stainless steel pad. The urethane provides excellent protection against damage on delicate work surfaces. Tapped hole mounting.

see our website for our full range:  
**wixroyd.com**

### Grippers



**High Speed Tool Steel**

Manufactured from M-2 high speed tool steel, hardened to Rc 60/62 with black oxide finish. Mount via tapped hole, counter bored hole or a flat on the outside diameter for set screw mounting.

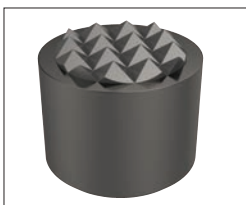

**Carbide Tipped**

Constructed with high impact carbide pad brazed to a heat treated alloy steel body. Mounts via tapped hole or a flat on the outside diameter for set screw mounting.

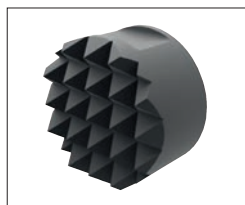

**Solid Carbide**

Manufactured from high impact carbide in a solid gripper pad or as a solid gripper body with a threaded brazed-in steel insert. Mount via tapped hole or a flat on the outside diameter for set screw mounting.

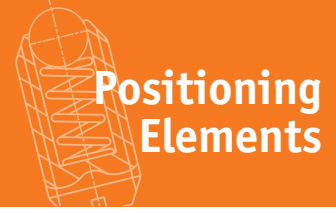
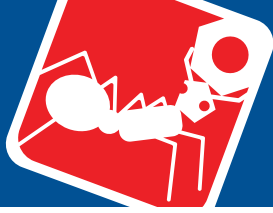

### Tooth Pattern Specifications

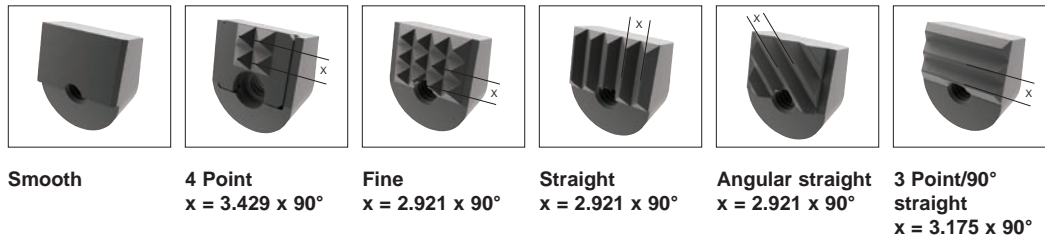

### Angular Grippers

Our carbide and hardened steel grippers are available with a variety of tooth patterns, as specified on the product data tables.

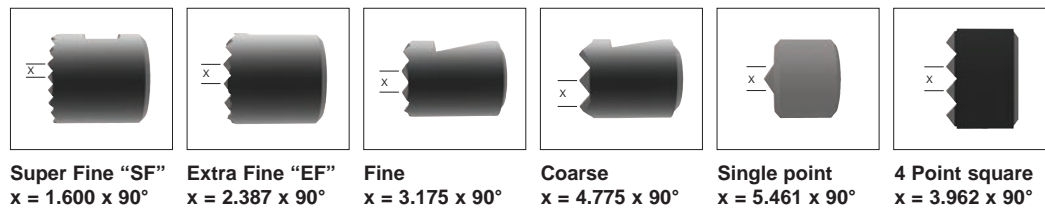

### Round/Square Grippers

### Mounting options

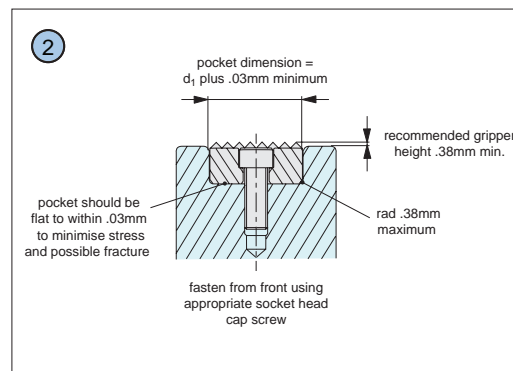
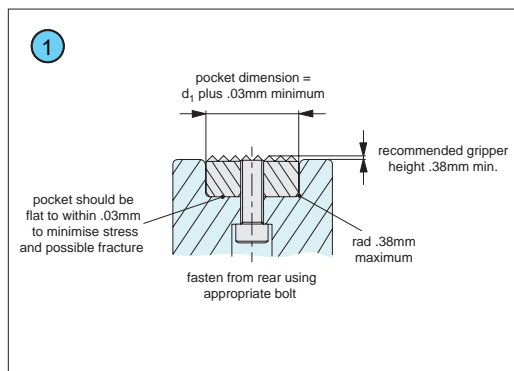

### Mounting Options for Carbide and Hardened Steel Grippers and Inserts.

Our carbide grippers and inserts can be installed in a number of different ways, the most suitable mounting method depends upon the specific insert – please refer to the product data table for specific information.

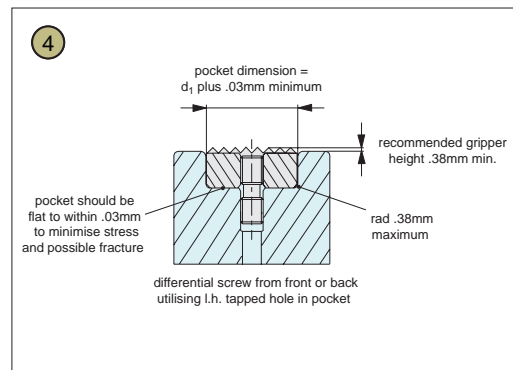
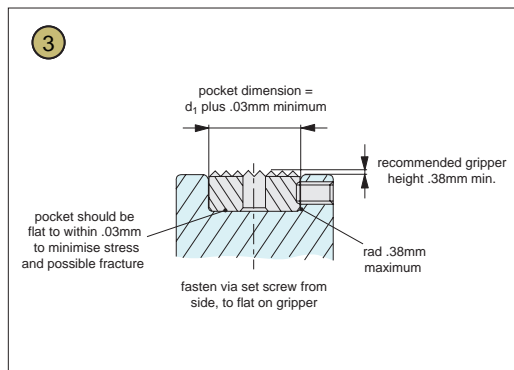

1 Round or square grippers and rest pads with tapped blind-hole or through hole tap.

2 Round or square grippers and rest pads with counter-bored hole.

3 Round grippers with flat on the O.D. for set screw mounting. Also square gripper mounting.

4 Round or square grippers with through tapped hole.

5 Round or square carbide pads.

6 Counter-bored edge grippers.

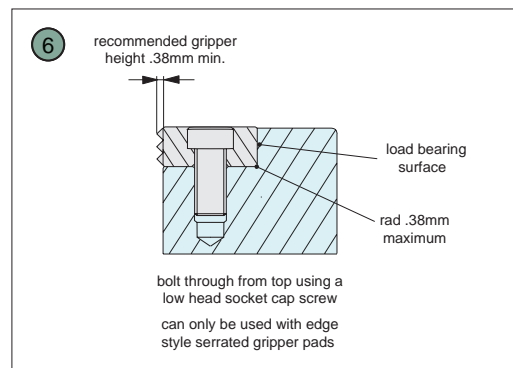
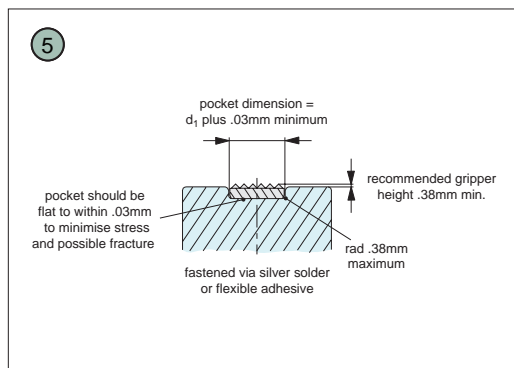



**A Range of Specialist Gripping Pads to Suit Your Application**

**Urethane Coated**



Unique urethane coat prevents marking of delicate components during machining or manipulation by robots. The urethane pad is permanently bonded to the stainless steel body of the gripping pad. With a bubbled texture, air is able to escape and hence avoid any suction action - enabling easy releasing of parts.

These are available in three different urethane durometers.



**35 durometer:**  
Pencil rubber top



**60 durometer:**  
Car tyre



**80 durometer:**  
Skateboard wheel

**Abrasive Diamond Coated**

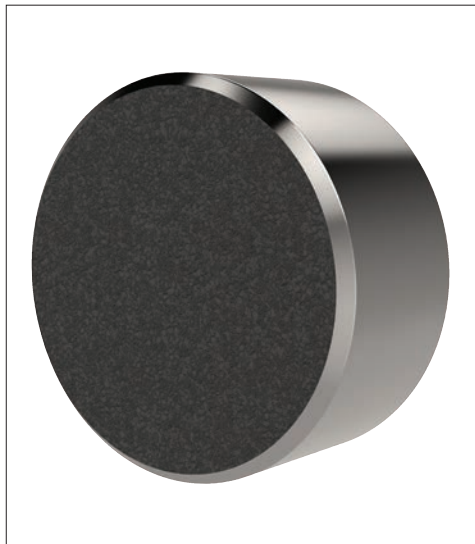

To improve handling of smooth or slippery components, with a minimum of clamping pressure, our abrasive diamond coated pads provide an excellent solution.

Diamond powders are permanently fused to a 17-4 stainless pad, to provide an abrasive surface comparable to 100 grit value.



**Sandpaper of 100 grit texture**

**Stainless Pads**



Pads of 17-4 Stainless, hardened to RC 43/46 provide solutions to applications where material selection is of greater importance; for example nuclear or food processing or pharmaceutical applications.