

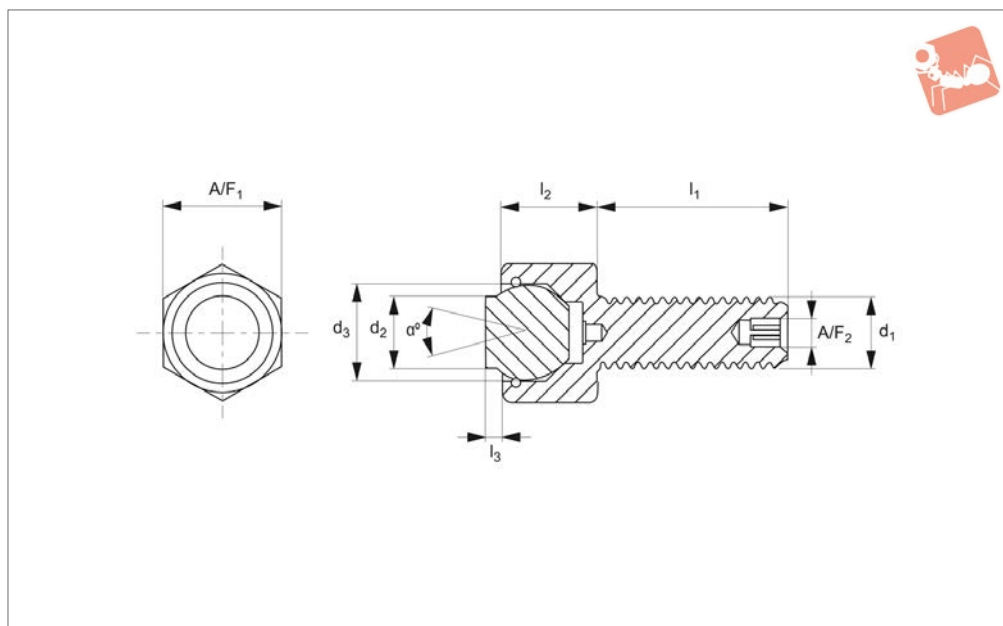

Grippers - Self Aligning - HTS

flat - threaded bolt

Grippers & Rest Pads



35530.2

GRIPPERS & REST PADS

Material

Body: steel, hardened to HRC 43/46, black oxide finish.

Ball: M2 high speed steel, hardened to HRC 60/62.

Viton o-ring holds ball in place and prevents ingress of other material.

Technical Notes

These adjustable self-aligning pads serve

as stops, supports and thrust elements in jigs and fixtures. They can also be fitted to existing workholding elements.

Use low-profile hexagon nut (DIN 439B) for adjustment and securing if required.

Order No.	d ₁	d ₂	d ₃	l ₁	l ₂ ±0.05	l ₃	Swivel angle α °	Load rating kg	A/F ₁	A/F ₂
35530.W0101	M6X1,0	6.0	7	12	8.0	1.5	28	935	10	-
35530.W0102	M6X1,0	6.0	7	12	8.0	3.0	28	935	10	-
35530.W0103	M6X1,0	6.0	7	25	8.0	1.5	28	935	10	-
35530.W0104	M6X1,0	6.0	7	25	8.0	3.0	28	935	10	-
35530.W0105	M6X1,0	6.0	7	40	8.0	1.5	28	935	10	-
35530.W0106	M6X1,0	6.0	7	40	8.0	3.0	28	935	10	-
35530.W0107	M8X1,25	8.5	10	12	11.5	1.5	24	1565	13	-
35530.W0108	M8X1,25	8.5	10	12	11.5	3.0	24	1565	13	-
35530.W0109	M8X1,25	8.5	10	25	11.5	1.5	24	1565	13	-
35530.W0110	M8X1,25	8.5	10	25	11.5	3.0	24	1565	13	-
35530.W0111	M8X1,25	8.5	10	40	11.5	1.5	24	1565	13	-
35530.W0112	M8X1,25	8.5	10	40	11.5	3.0	24	1565	13	-
35530.W0113	M10X1,5	10.0	13	15	13.0	4.0	42	1902	17	3
35530.W0114	M10X1,5	10.0	13	15	13.0	6.0	42	1902	17	3
35530.W0115	M10X1,5	10.0	13	30	13.0	4.0	42	1902	17	3
35530.W0116	M10X1,5	10.0	13	30	13.0	6.0	42	1902	17	3
35530.W0117	M10X1,5	10.0	13	50	13.0	4.0	42	1902	17	3
35530.W0118	M10X1,5	10.0	13	50	13.0	6.0	42	1902	17	3
35530.W0119	M12X1,75	12.0	15	20	15.0	4.0	45	3006	19	5
35530.W0120	M12X1,75	12.0	15	20	15.0	6.0	45	3006	19	5
35530.W0121	M12X1,75	12.0	15	40	15.0	4.0	45	3006	19	5
35530.W0122	M12X1,75	12.0	15	40	15.0	6.0	45	3006	19	5
35530.W0123	M12X1,75	12.0	15	60	15.0	4.0	45	3006	19	5
35530.W0124	M12X1,75	12.0	15	60	15.0	6.0	45	3006	19	5
35530.W0125	M16X2,0	16.0	20	25	19.0	4.0	40	5073	24	6
35530.W0127	M16X2,0	16.0	20	50	19.0	4.0	40	5073	24	6
35530.W0129	M16X2,0	16.0	20	80	19.0	4.0	40	5073	24	6

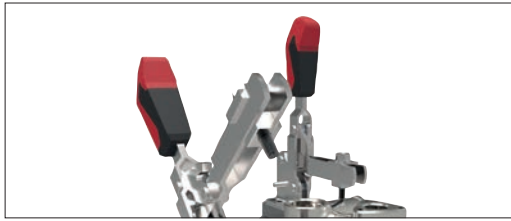

Grippers enhance workholding for multiple machining operations.

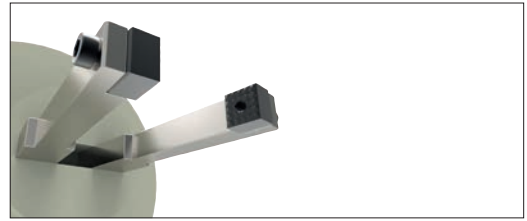

Grippers increase handling capability.

Pads and Gripper Options

Pads

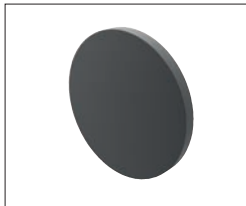

Solid Carbide

High impact carbide pads, can be brazed or bonded into place.



Carbide Tipped

Constructed with high impact carbide pad brazed to a heat treated alloy steel body. Mount via tapped hole or a flat on the outside diameter for set screw mounting.



Hardened Steel

Made from 8620 steel, carburized and hardened to Rc 58/60 1.2mm with black oxide finish. Mount via tapped or counter bored hole.



Non-marking Thermoplast

Made from white thermoplast. Mount via tapped or counter bored hole.



Stainless Steel

Pad from 17-4 stainless steel, hardened to Rc 43/46. Mount via tapped or counter bored hole.

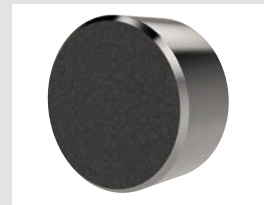

Abrasive Diamond Surface

Abrasive surface permanently fused to a 17-4 stainless steel pad, hardened to Rc 43/46. The surface texture is comparable to a 100 grit abrasive. Mount via tapped or counter bored hole.



Soft Urethane Surface

Urethane surface is permanently bonded to a 300 series stainless steel pad. The urethane provides excellent protection against damage on delicate work surfaces. Tapped hole mounting.

see our website for our full range:
wixroyd.com

Grippers



High Speed Tool Steel

Manufactured from M-2 high speed tool steel, hardened to Rc 60/62 with black oxide finish. Mount via tapped hole, counter bored hole or a flat on the outside diameter for set screw mounting.

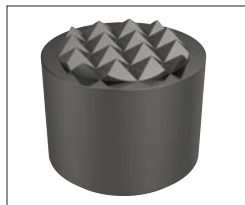

Carbide Tipped

Constructed with high impact carbide pad brazed to a heat treated alloy steel body. Mounts via tapped hole or a flat on the outside diameter for set screw mounting.

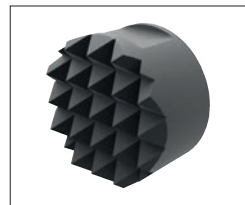

Solid Carbide

Manufactured from high impact carbide in a solid gripper pad or as a solid gripper body with a threaded brazed-in steel insert. Mount via tapped hole or a flat on the outside diameter for set screw mounting.



A Range of Specialist Gripping Pads to Suit Your Application



Unique urethane coat prevents marking of delicate components during machining or manipulation by robots. The urethane pad is permanently bonded to the stainless steel body of the gripping pad. With a bubbled texture, air is able to escape and hence avoid any suction action - enabling easy releasing of parts.

Urethane Coated

These are available in three different urethane durometers.



35 durometer:
Pencil rubber top



60 durometer:
Car tyre



80 durometer:
Skateboard wheel

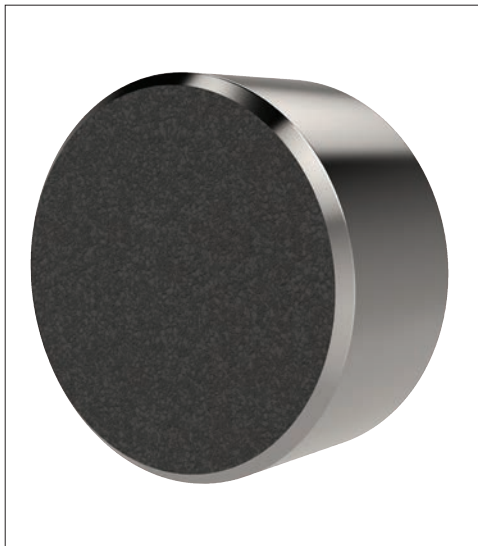

To improve handling of smooth or slippery components, with a minimum of clamping pressure, our abrasive diamond coated pads provide an excellent solution.

Abrasive Diamond Coated

Diamond powders are permanently fused to a 17-4 stainless pad, to provide an abrasive surface comparable to 100 grit value.



Sandpaper of 100
grit texture

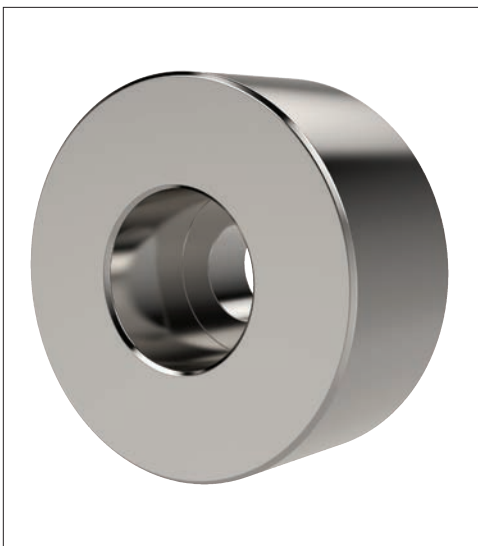

Pads of 17-4 Stainless, hardened to RC 43/46 provide solutions to applications where material selection is of greater importance; for example nuclear or food processing or pharmaceutical applications.

Stainless Pads