

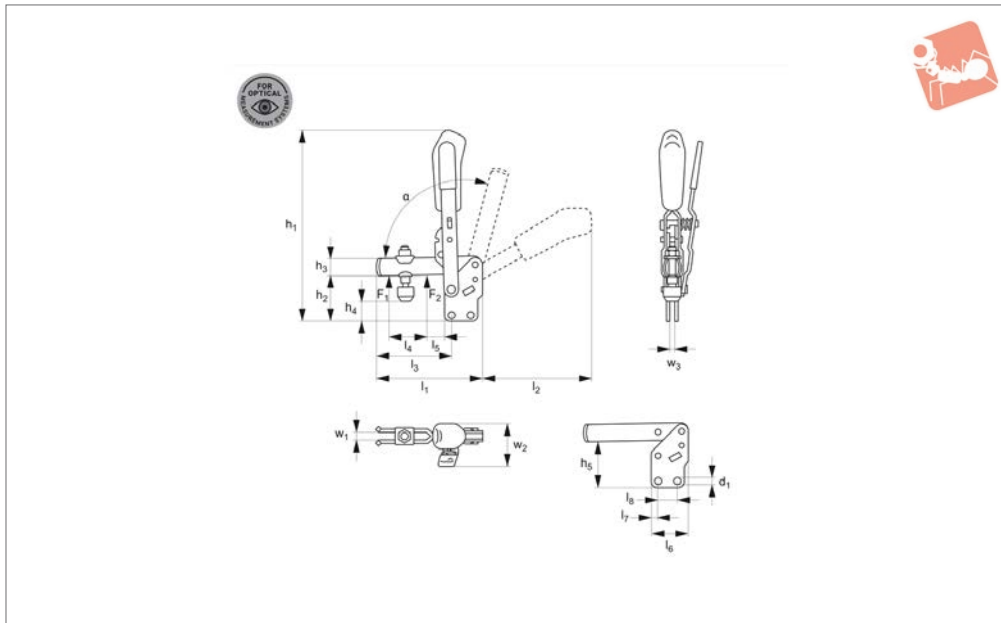

# Horizontal Acting Toggle Clamps

black - open arm - vertical base - safety lever

# Optical Measuring Toggle



**40060.2**

OPTICAL MEASURING TOGGLE CLAMPS

### Material

Body: steel matt black.  
 Bushes: case hardened and pre-lubricated.  
 Ergonomic soft feel, oil-resistant handle with large grip area.  
 Supplied complete with clamping screw (with rubber pad).

### Technical Notes

For fastening to mounting plates, etc.  
 Opening angle (symbol $\alpha$ /symbol $\alpha$ /symbol $\alpha$ /symbol $\alpha$ \*) can be changed by pressing in a stop pin on the clamp body.  
**For optical analysis applications.**

### Tips

Designed specifically for clamping of parts during photometric measurement. Uniform matt black surface prevents reflection, enabling easy „knocking-out“ of the clamp during optical analysis of a component.

Order No.	Size	F <sub>1</sub> kN	F <sub>2</sub> kN	Clamping screw	h <sub>1</sub>	h <sub>2</sub>	h <sub>3</sub>	h <sub>4</sub> min.	h <sub>4</sub> max.	h <sub>5</sub>	l <sub>1</sub>	l <sub>2</sub>	Weight g
<b>40060.W0006</b>	3	1.4	2.5	M 8x63	200	48	18	16.5	25	41	112	114	470
Order No.	l <sub>3</sub>	l <sub>4</sub>	l <sub>5</sub>	l <sub>6</sub>	l <sub>7</sub>	l <sub>8</sub>	w <sub>1</sub>	w <sub>2</sub>	w <sub>3</sub>	d <sub>1</sub>	$\alpha$	$\alpha^*$	
<b>40060.W0006</b>	79	37	19	40	7.5	20	8	45.5	6	7.5	105°	60°	



## Meeting the Needs of Component Clamping During Optical Measurements



The black toggle clamps are especially suited for optical workpiece measurements.

The complete matt-black surface of the clamps prevents reflections. As a result, in the later evaluation of the measurement results on the PC, all un-needed clamp parts can be "knocked out" and only the actual workpiece is visible.

These toggle clamps are blackened using the Vario-Spektrox® process. This offers effective protection against corrosion and film rust formation. In addition, this process is less environmentally damaging.

### Component Clamping

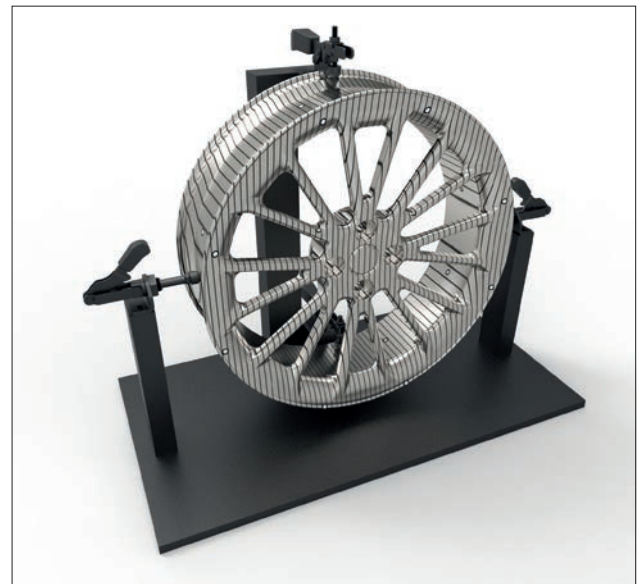

### Optical Measurement Process

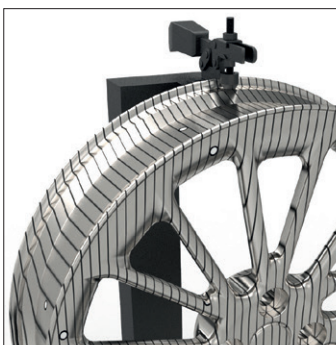

#### Marking and measuring

For overlaying of several pictures, circular markings are attached to the object. A stripe pattern is projected onto the object surface by a white-light projector and photographed by two cameras from different angles of view.

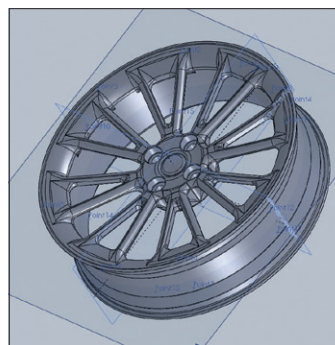

#### Evaluation

Within seconds, highly precise 3D coordinates of up to 4 million object points per measurement are calculated. For this, the black parts such as the toggle clamps are "suppressed".

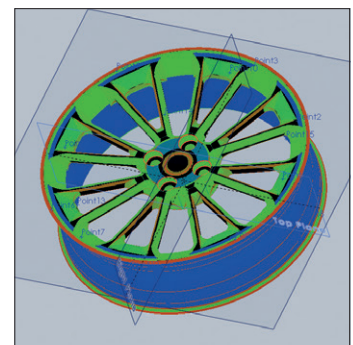

#### Visualisation

Variances for the CAD are calculated. The 3D coordinates of the measurement points can be measured exactly and visualised in colour.

The complete 3D data set and the comparison results can be exported into common formats for further processing.