

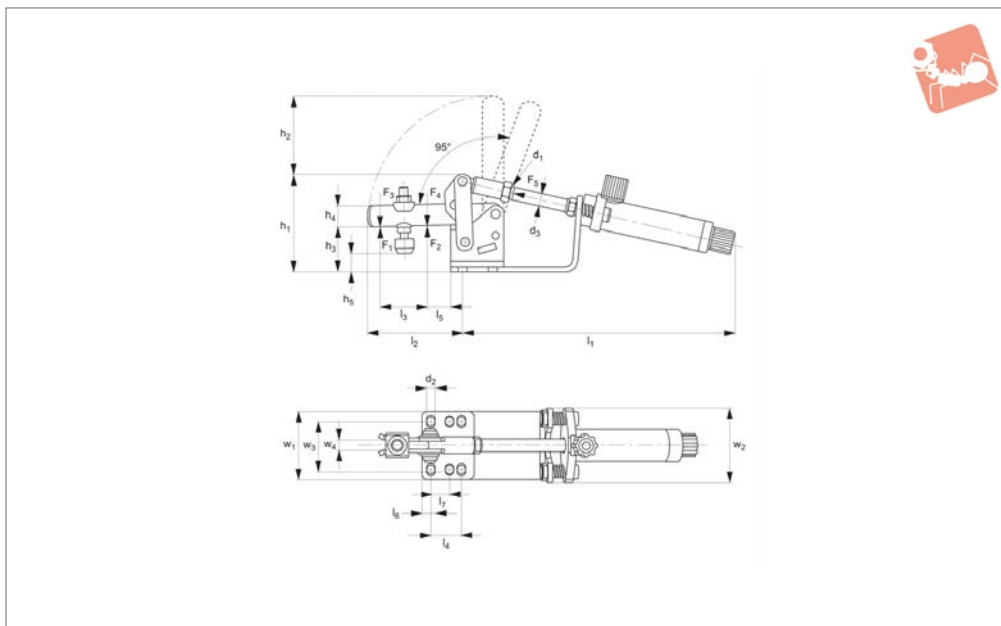

Pneumatic Toggle Clamp with horizontal cylinder attachment

Pneumatic Toggle Clamps



47040

PNEUMATIC TOGGLE CLAMPS

Material

Body: steel, zinc plated and galvanised.
 Bushes: case hardened and greased.
 Rivets: stainless steel.
 Complete with tempered, galvanized clamping screw.

Technical Notes

Bearings are pre-lubricated.

Clamp ready for installation and consists of:

- vertical toggle clamp no. 40000 (without handle)
- Plastic pneumatic cylinder, double acting.

Vn = air consumption per double stroke in dm³ at 6 bar.

Tips

The console is self-supporting and must be clear of other surfaces. There is a valve for controlling the speed of operation.

F₃ and F₄ = max. clamping force at 6 bar.

Order No.	Size	F ₁ kN	F ₂ kN	F ₃ kN	F ₄ kN	F ₅ kN	Clamping screw	d ₁	d ₂	d ₃	h ₁	h ₂	h ₃	Weight g
47040.W0000	0	0.5	0.7	0.07	0.09	38	M 4x25	M 4	4.5	4	46	23.0	20	125
47040.W0001	1	0.8	1.1	0.13	0.18	60	M 5x30	M 6	4.5	6	50	34.5	22	400
47040.W0002	2	1.0	1.2	0.35	0.50	170	M 6x35	M 8	5.4	8	63	42.5	27	600
47040.W0003	3	1.4	2.5	0.55	1.00	265	M 8x45	M10x1,25	7.1	10	64	69.0	38	800

Order No.	h ₄	h ₅ min.	h ₅ max.	l ₁	l ₂	l ₃	l ₄	l ₅	l ₆	l ₇	Vn dm ³	w ₁	w ₂	w ₃	w ₄
47040.W0000	8	-1	6	132	31	14	13.5	5.5	5.0	-	0.03	33	29	23	4
47040.W0001	10	-2	5	145	38	18	16.0	6.0	6.0	-	0.06	34	33	24	5
47040.W0002	12	1	8	163	52	25	20.0	11.0	6.0	12.5	0.17	44	54	27	6
47040.W0003	18	7	16	205	78	37	20.0	19.0	7.5	-	0.30	50	59	32	8