

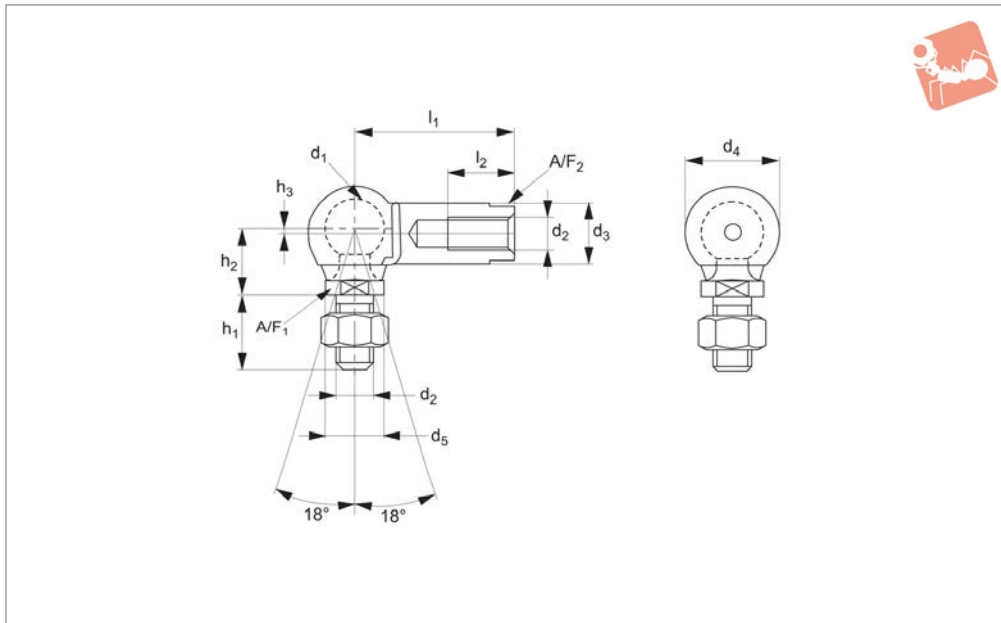

Ball and Socket Joint

left hand thread- with flats on housing

Ball and Socket Joints



65510

BALL AND SOCKET JOINTS

Material

Stud: carbon steel, sealing cap: neoprene.
Housing: steel (9sMnPb28), silver zinc plated.

Technical Notes

To DIN 71802 form CS, supplied with hexagon nut.

Safety ring aids the retention of the ball stud in the housing.

*M14x1,5 is a fine pitch thread.

Tips

Stud: right hand thread.
Housing: left hand thread

Important Notes

Thread is not full length. There is a min 1.5mm unthreaded shank. If using part without the supplied nut, then please consider a counterbore to accommodate the unthreaded shank.

Order No.	Thread hand	d ₁	l ₁ ±0.3	d ₂	d ₃ ±0.5	d ₄ ±0.5	d ₅ ±0.5	Weight g
65510.W0005	Left	8	22	M5	8	12.8	8	15.2
65510.W0006	Left	10	25	M6	10	14.8	10	25.2
65510.W0008	Left	13	30	M8	13	19.3	13	53.1
65510.W0010	Left	16	35	M10	16	24.0	16	103.8
65510.W0012	Left	16	35	M12	16	24.0	16	103.8
65510.W0014	Left	19	45	M14x1,5	22	30.0	22	220.9
65510.W0015	Left	19	45	M14	22	30.0	22	220.9
65510.W0016	Left	19	45	M16	22	30.0	22	220.9

Order No.	h ₁ ±0.3	h ₂ ±0.3	h ₃	l ₂ min.	A/F ₁	A/F ₂	Extraction force kg min.	Static load kg max.	Dyn. load C kg max.	Force required for movement kg max.
65510.W0005	10.0	9	0.65	10.2	7	-	3	50	20	3
65510.W0006	12.5	11	0.70	11.5	8	-	4	100	40	4
65510.W0008	16.5	13	1.15	14.0	11	-	6	200	80	6
65510.W0010	20.0	16	1.15	15.5	13	-	8	400	160	8
65510.W0012	20.0	16	1.15	15.5	13	-	8	400	160	8
65510.W0014	28.0	20	0.50	21.5	16	19	10	800	320	10
65510.W0015	28.0	20	0.50	21.5	16	19	10	800	320	10
65510.W0016	28.0	20	0.50	21.5	16	19	10	800	320	10