

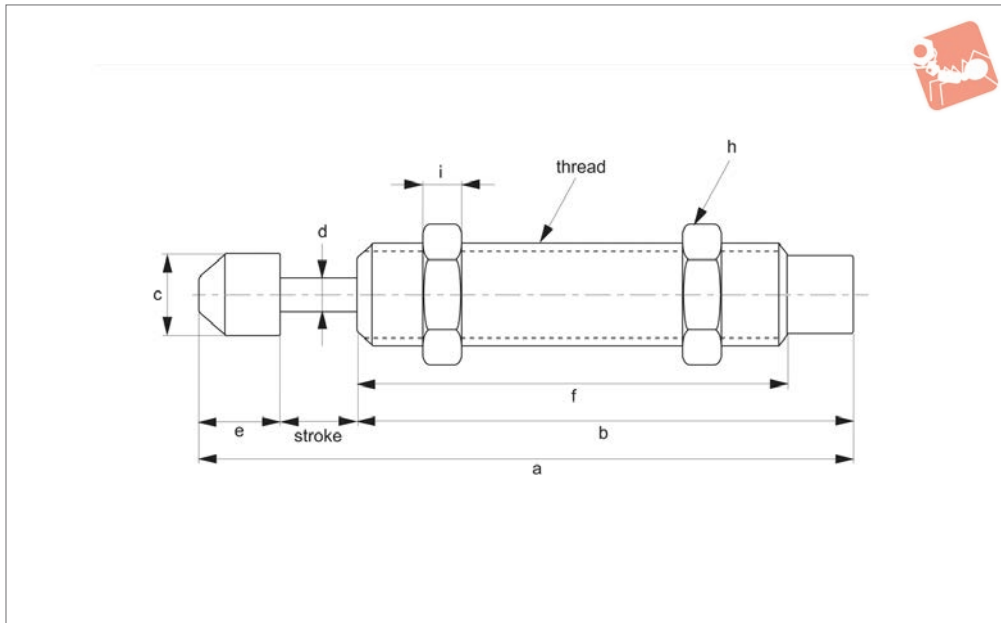

# Minature Shock Absorbers, Self M8 - M12, non-adjustable

## Shock Absorbers



**68001**

SHOCK ABSORBERS

### Material

Outer Tube: STKM11A, hardened and blackened.  
Piston Rod: AISI 1045 hardened to HV940°, chrome plated.  
Return Spring: DIN GWP.  
Muffler Cap: urethane rubber.  
Seal: nitrile rubber.

### Technical Notes

Supplied with rubber muffler cap as standard, this is removable - see introductory technical notes for guidance.

### Tips

Select High Impact Speed model for hard impact at start of stroke. For hard set down

at end of stroke choose a Medium or Low Impact Speed model.

### Important Notes

For correct product selection refer to Product Selection Formulae and Calculation pages, and associated Capacity & Selection Charts.

Order No.	Stroke mm	Nm per cycle (Et) Nm max.	Per hour (ETc) Nm max.	Effective mass (Me) kg max.	Impact speed (v) m/s max.	Impact speed (v) m/s max.	Operating temperature °C	Thre ad	a	b	c	d	e	f	h	i	Weig ht g
<b>68001.W0109</b>	10	4	108 00	3.0	Low	0.5	-10 to +80	M10 x0,7 5	66.8	49.5	8.0	3.0	8.0	44.5	12.7	3	20.0

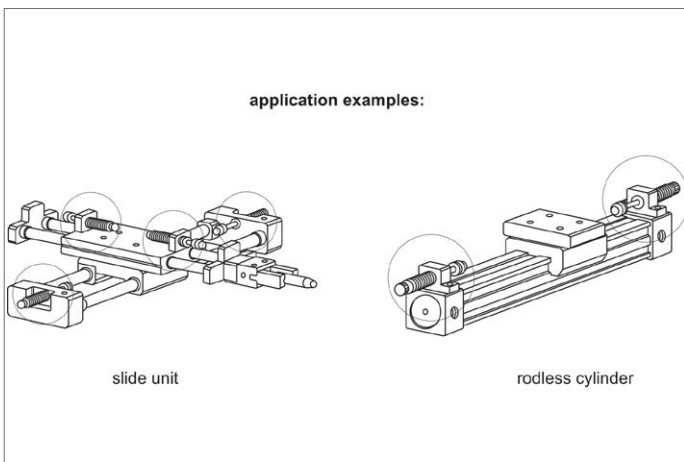



## 68002

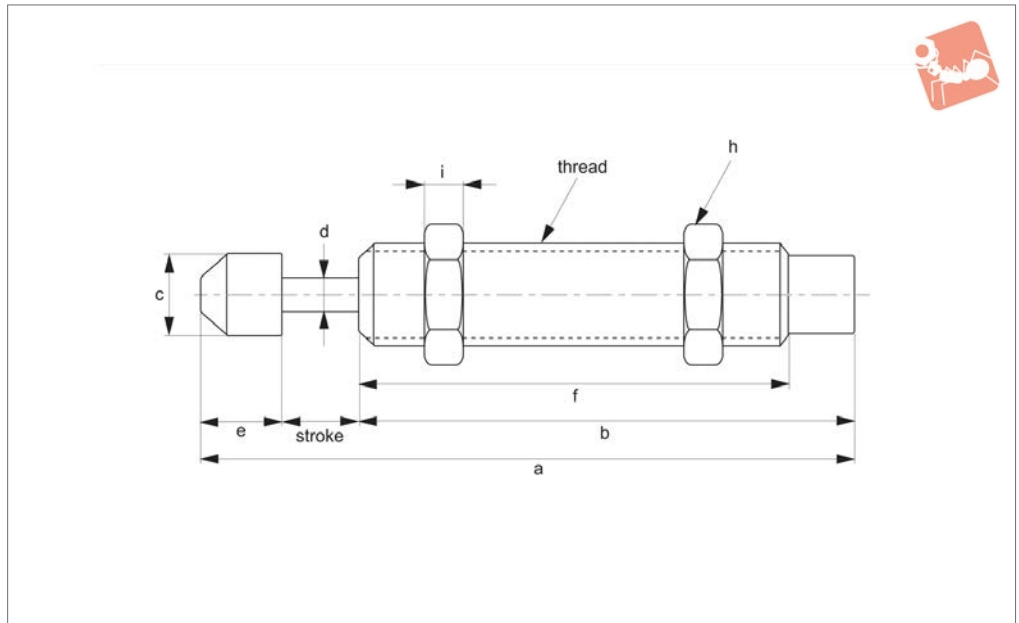

### Material

Outer Tube: STKM11A, hardened and blackened.

Piston Rod: AISI 1045 hardened to HV940°, chrome plated.

Return Spring: DIN GWP.

Muffler Cap: urethane rubber. Seal: nitrile rubber.

### Technical Notes

Supplied with rubber muffler cap as standard, this is removable - see introductory technical notes for guidance.

### Tips

Select High Impact Speed model for hard impact at start of stroke. For hard set down

at end of stroke choose a Medium or Low Impact Speed model.

### Important Notes

For correct product selection refer to Product Selection Formulae and Calculation pages, and associated Capacity & Selection Charts.

Order No.	Stroke mm	Nm per cycle (Et)		Per hour (ETc)	Effective mass (Me)	Impact speed (v)	Impact speed (v)	Operating temperature	Weight
		Nm max.	Nm max.						
68002.W0140	8	12	22000		6	High	3.0	-10 to +80	65
68002.W0141	12	15	30000		8	High	3.0	-10 to +80	80
68002.W0142	12	15	30000		50	Med	1.5	-10 to +80	80
68002.W0143	12	15	30000		100	Low	0.8	-10 to +80	80
68002.W0144	16	20	35000		10	Low	3.0	-10 to +80	85
68002.W0145	16	20	35000		70	Low	1.5	-10 to +80	85
68002.W0146	16	20	35000		150	Low	0.8	-10 to +80	85
68002.W0147	16	20	35000		10	High	3.0	-10 to +80	80
68002.W0148	16	20	35000		70	Med	1.5	-10 to +80	80
68002.W0149	16	20	35000		150	Low	0.8	-10 to +80	80
68002.W0198	20	20	35000		10	High	3.0	-10 to +80	95
68002.W0199	20	20	35000		70	Med	1.5	-10 to +80	95
68002.WX200	10	16	42000		30	Low	3.5	-10 to +80	165
68002.W0200	20	20	35000		150	Low	0.8	-10 to +80	95
68002.W0201	20	40	40000		30	High	3.5	-10 to +80	215
68002.W0202	20	40	40000		200	Med	2.0	-10 to +80	215
68002.W0203	20	40	40000		700	Low	1.0	-10 to +80	215
68002.W0204	30	50	48000		30	High	3.5	-10 to +80	220
68002.W0205	30	50	48000		200	Med	2.0	-10 to +80	220
68002.W0206	30	50	48000		700	Low	1.0	-10 to +80	220
68002.W0207	50	60	60000		60	High	3.5	-10 to +80	300
68002.W0208	50	60	60000		400	Med	2.0	-10 to +80	300
68002.W0209	50	60	60000		1200	Low	1.0	-10 to +80	300

Order No.	Thread	a	b	c	d	e	f	h	i
68002.W0140	M14x1,5	73.5	55.0	12.0	4.0	11.2	50.5	19	5
68002.W0141	M14x1,5	98.5	76	12	4	10.5	67	19	5

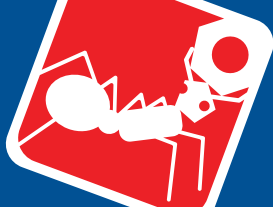

# Shock Absorbers, Self Compensating

M14 - M20, non adjustable

## Shock Absorbers

Order No.	Thread	a	b	c	d	e	f	h	i
68002.W0142	M14x1,5	98.5	76	12	4	10.5	67	19	5
68002.W0143	M14x1,5	98.5	76	12	4	10.5	67	19	5
68002.W0144	M14x1,5	122.2	95.0	12.0	4.0	11.2	86.0	19.0	5.0
68002.W0145	M14x1,5	122.2	95.0	12.0	4.0	11.2	86.0	19.0	5.0
68002.W0146	M14x1,5	122.2	95.0	12.0	4.0	11.2	86.0	19.0	5.0
68002.W0147	M14x1,5	102.5	76	12	4	10.5	67	19	5
68002.W0148	M14x1,5	102.5	76	12	4	10.5	67	19	5
68002.W0149	M14x1,5	102.5	76	12	4	10.5	67	19	5
68002.W0198	M14x1,5	125.5	95	12	4	10.5	86	19	5
68002.W0199	M14x1,5	125.5	95	12	4	10.5	86	19	5
68002.WX200	M16x1,5	68.0	58.0	10.0	5.0	8.0	40.0	19.0	6.0
68002.W0200	M14x1,5	125.5	95	12	4	10.5	86	19	5
68002.W0201	M20x1,5	145.8	110	18	6	15.8	101	26	7
68002.W0202	M20x1,5	145.8	110	18	6	15.8	101	26	7
68002.W0203	M20x1,5	145.8	110	18	6	15.8	101	26	7
68002.W0204	M20x1,5	158.8	113	18	6	15.8	104	26	7
68002.W0205	M20x1,5	158.8	113	18	6	15.8	104	26	7
68002.W0206	M20x1,5	158.8	113	18	6	15.8	104	26	7
68002.W0207	M20x1,5	232.8	167	18	6	15.8	158	26	7
68002.W0208	M20x1,5	232.8	167	18	6	15.8	158	26	7
68002.W0209	M20x1,5	232.8	167	18	6	15.8	158	26	7

SHOCK ABSORBERS

application examples:

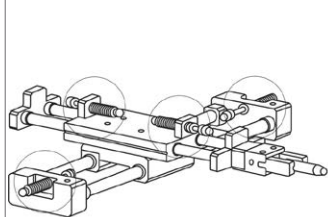

robot for plastic injection molding machine

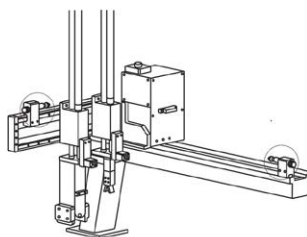

slide unit



## 68003

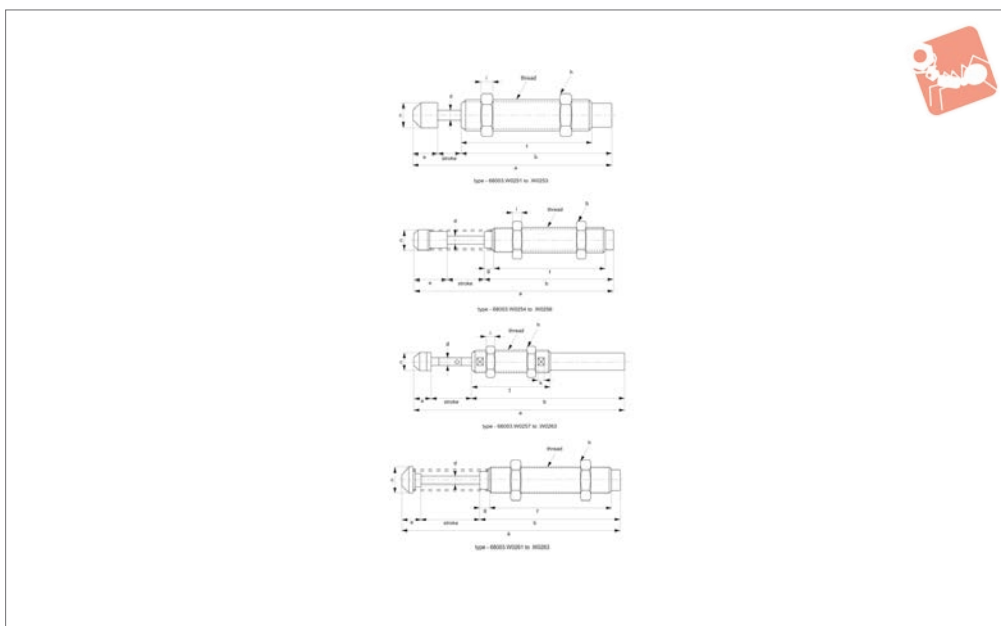

### Material

Outer Tube: STKM11A, hardened and blackened.

Piston Rod: AISI 1045 hardened to HV940°, chrome plated.

Return Spring: DIN GWP.

Muffler Cap: urethane rubber. **Seal:** nitrile rubber.

### Technical Notes

Supplied with rubber muffler cap as standard, this is removable - see introductory technical notes for guidance.

### Tips

Select High Impact Speed model for hard impact at start of stroke. For hard set down

at end of stroke choose a Medium or Low Impact Speed model.

### Important Notes

For correct product selection refer to Product Selection Formulae and Calculation pages, and associated Capacity & Selection Charts.

Order No.	Stroke mm	Nm per cycle (Et)		Per hour (ETc) Nm max.	Effective mass (Me) kg max.	Impact speed (v)	Impact speed (v) m/s max.	Operating temperature °C	Weight g
		Nm	Nm max.						
68003.W0251	25	80		54000	200	High	4.0	-10 to +80	330
68003.W0252	25	80		54000	800	Med	2.5	-10 to +80	330
68003.W0253	25	80		54000	1500	Low	1.0	-10 to +80	330
68003.W0254	40	120		75000	300	High	4.0	-10 to +80	430
68003.W0255	40	120		75000	1200	Med	2.5	-10 to +80	430
68003.W0256	40	120		75000	2000	Low	1.0	-10 to +80	430
68003.W0257	50	98		90000	15	High	4.0	-10 to +80	435
68003.W0258	50	98		90000	40	Med	2.5	-10 to +80	435
68003.W0259	50	98		90000	160	Low	1.0	-10 to +80	435
68003.W0261	80	150		120000	20	High	4.0	-10 to +80	535
68003.W0262	80	150		120000	50	Med	2.5	-10 to +80	535
68003.W0263	80	150		120000	200	Low	1.0	-10 to +80	535
68003.W0361	60	250		120000	400	High	4.0	-10 to +80	1,030
68003.W0362	60	250		120000	1500	Med	2.5	-10 to +80	1,030
68003.W0363	60	250		120000	2400	Low	1.0	-10 to +80	1,030

Order No.	Thread	a	b	c	d	e	f	h	g	i	j	k
68003.W0251	M25x1,5	155.0	111.0	22.0	8	19.5	101.0	32	-	9	-	-
68003.W0252	M25x1,5	155.0	111.0	22.0	8	19.5	101.0	32	-	9	-	-
68003.W0253	M25x1,5	155.0	111.0	22.0	8	19.5	101.0	32	-	9	-	-
68003.W0254	M25x1,5	214.0	127.0	22.0	8	36.0	117.0	32	10	9	-	-
68003.W0255	M25x1,5	214.0	127.0	22.0	8	36.0	117.0	32	10	9	-	-
68003.W0256	M25x1,5	214.0	127.0	22.0	8	36.0	117.0	32	10	9	-	-
68003.W0257	M25x1,5	239.5	170.5	22.0	8	19.5	100.0	32	-	9	-	-
68003.W0258	M25x1,5	239.5	170.5	22.0	8	19.5	100.0	32	-	9	-	-
68003.W0259	M25x1,5	239.5	170.5	22.0	8	19.5	100.0	32	-	9	-	-
68003.W0261	M25x1,5	336.0	237.0	22.0	8	19.5	100.0	32	-	9	23	11



# Shock Absorbers, Self Compensating

M25 - M36, non-adjustable

## Shock Absorbers

Order No.	Thread	a	b	c	d	e	f	h	g	i	j	k
<b>68003.W0262</b>	M25x1,5	336.0	237.0	22.0	8	19.5	100.0	32	-	9	23	11
<b>68003.W0263</b>	M25x1,5	336.0	237.0	22.0	8	19.5	100.0	32	-	9	23	11
<b>68003.W0361</b>	M36x1,5	248.0	162.0	35.5	10	26.0	134.0	46	17	15	23	11
<b>68003.W0362</b>	M36x1,5	248.0	162.0	35.5	10	26.0	134.0	46	17	15	23	11
<b>68003.W0363</b>	M36x1,5	248.0	162.0	35.5	10	26.0	134.0	46	17	15	23	11

SHOCK ABSORBERS



## 68004

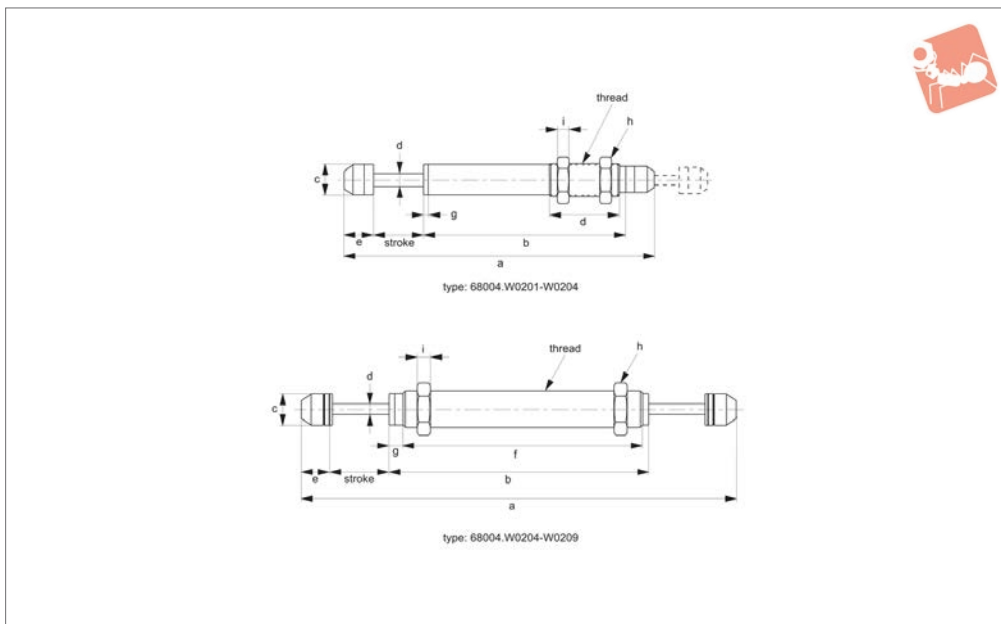

### Material

Outer Tube: STKM11A, hardened and blackened.

Piston Rod: AISI 1045 hardened to HV940°, chrome plated.

Return Spring: DIN GWP.

Muffler Cap: urethane rubber. **Seal:** nitrile rubber.

### Technical Notes

Supplied with rubber muffler cap as standard, this is removable - see introductory technical notes for guidance.

### Tips

Select High Impact Speed model for hard impact at start of stroke. For hard set down

at end of stroke choose a Medium or Low Impact Speed model.

### Important Notes

For correct product selection refer to Product Selection Formulae and Calculation pages, and associated Capacity & Selection Charts.

Order No.	Stroke mm	Nm per cycle (Et)		Per hour (ETc)	Effective mass (Me)	Impact speed (v)		Operating temperature °C	Weight g
		Nm max.	Nm max.			kg max.	m/s max.		
68004.W0201	30	45	55000	40	High	3.5	-10 to +80	320	
68004.W0202	30	45	55000	300	Med	2.0	-10 to +80	320	
68004.W0203	30	45	55000	900	Low	1.0	-10 to +80	320	
68004.W0204	35	52	63000	40	High	3.5	-10 to +80	350	
68004.W0205	35	52	63000	200	Med	2.0	-10 to +80	350	
68004.W0206	35	52	63000	650	Low	1.0	-10 to +80	350	
68004.W0207	50	60	68000	60	High	3.5	-10 to +80	470	
68004.W0208	50	60	68000	210	Med	2.0	-10 to +80	470	
68004.W0209	50	60	68000	480	Low	1.0	-10 to +80	470	
68004.W0210	50	70	72000	530	Low	3.5	-10 to +80	480	

Order No.	Thread	a	b	c	d	e	f	h	g	i
68004.W0201	M20x1,5	183.6	123	18	6	15.8	44	26	3	7
68004.W0202	M20x1,5	183.6	123	18	6	15.8	44	26	3	7
68004.W0203	M20x1,5	183.6	123	18	6	15.8	44	26	3	7
68004.W0204	M20x1,5	224.6	123	18	5	15.8	42	26	5	7
68004.W0205	M20x1,5	224.6	123	18	5	15.8	42	26	5	7
68004.W0206	M20x1,5	224.6	123	18	5	15.8	42	26	5	7
68004.W0207	M20x1,5	276.6	145	18	6	15.8	134	26	8	7
68004.W0208	M20x1,5	276.6	145	18	6	15.8	134	26	8	7
68004.W0209	M20x1,5	276.6	145	18	6	15.8	134	26	8	7
68004.W0210	M20x1,5	313.8	172.8	17.8	6	20.5	11	26	16	7



# Shock Absorber Self Compensating M30, non-adustable

## Shock Absorbers

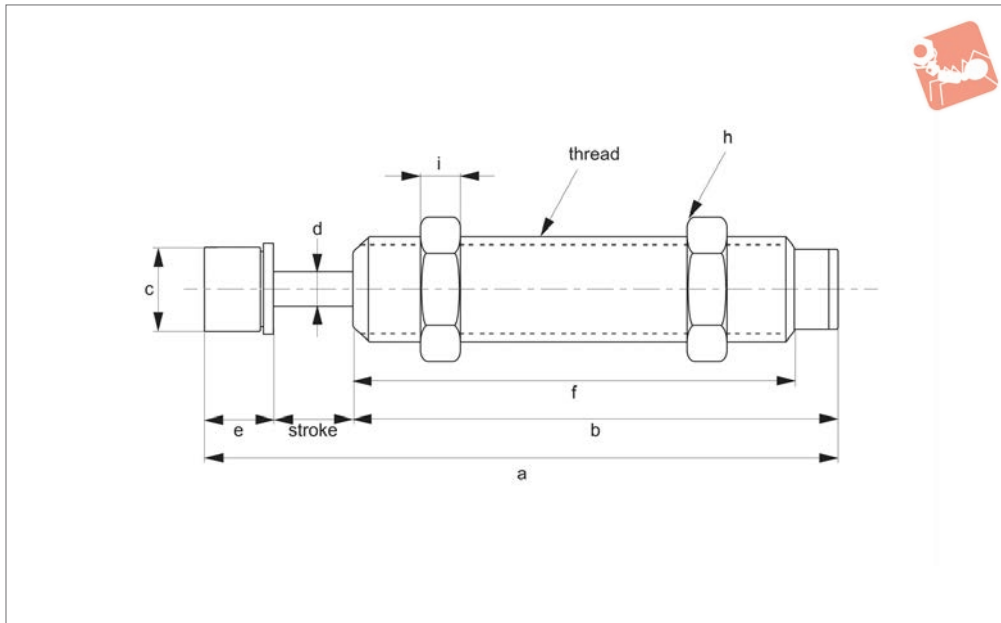

**68005**

SHOCK ABSORBERS

### Material

Outer Tube: STKM11A, hardened and blackened.

Piston Rod: AISI 1045 hardened to HV940°, chrome plated.

Return Spring: DIN GWP.

Muffler Cap: urethane rubber. **Seal:** nitrile rubber.

### Technical Notes

Supplied with rubber muffler cap as standard, this is removable - see introductory technical notes for guidance.

### Tips

Select High Impact Speed model for hard impact at start of stroke. For hard set down

at end of stroke choose a Medium or Low Impact Speed model.

### Important Notes

For correct product selection refer to Product Selection Formulae and Calculation pages, and associated Capacity & Selection Charts.

Order No.	Stroke mm	Nm per cycle (Et)		Per hour (ETc)		Effective mass (Me) kg max.	Impact speed (v)	Impact speed (v)		Weight g
		Nm max.	Nm max.	Nm max.	Nm max.			m/s max.	m/s max.	
<b>68005.W0301</b>	25	180	180	60000	60000	300	High	3.0	3.0	950
<b>68005.W0302</b>	25	180	180	60000	60000	700	Med	2.0	2.0	950
<b>68005.W0303</b>	25	180	180	60000	60000	1300	Low	1.0	1.0	950

Order No.	Operating temperature °C	Thread	a	b	c	d	e	f	h	i
<b>68005.W0302</b>	-10~+80	M30x1,5	151	106.5	27	10	19.5	94.5	36	14
<b>68005.W0303</b>	-10~+80	M30x1,5	151	106.5	27	10	19.5	94.5	36	14



## 68008

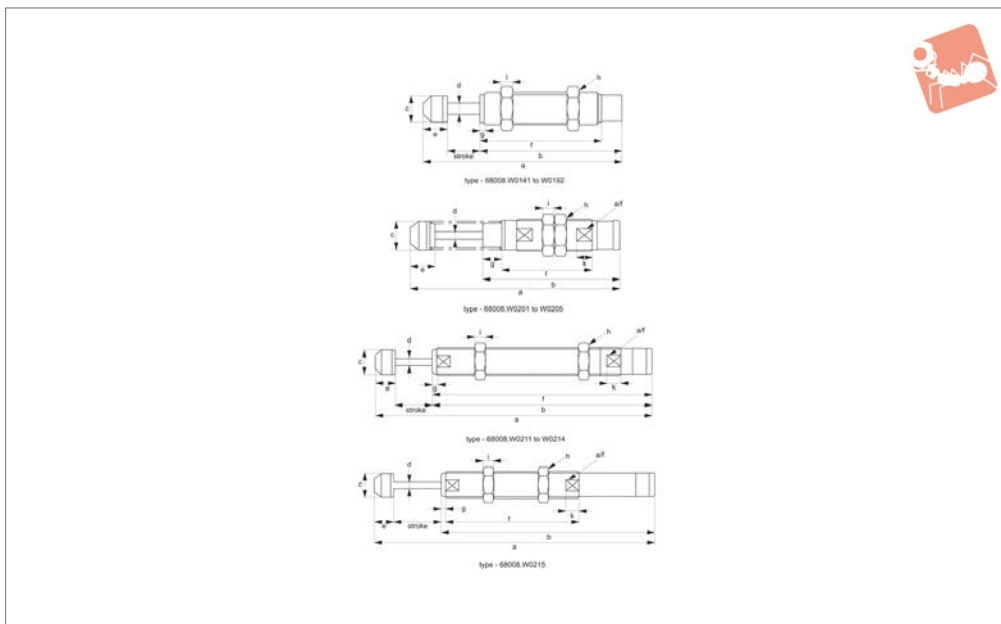

### Material

Outer Tube: STKM11A, hardened and blackened.

Piston Rod: AISI 1045 hardened to HV940°, chrome plated.

Return Spring: DIN GWP.

Muffler Cap: urethane rubber. **Seal:** nitrile rubber.

### Technical Notes

Supplied with rubber muffler cap as standard, this is removable - see introductory technical notes for guidance.

### Tips

Select High Impact Speed model for hard impact at start of stroke. For hard set down

at end of stroke choose a Medium or Low Impact Speed model.

### Important Notes

For correct product selection refer to Product Selection Formulae and Calculation pages, and associated Capacity & Selection Charts.

Order No.	Stroke mm	Nm per cycle (Et)		Per hour (ETc)	Effective mass (Me) kg max.	Impact speed (v)	Impact speed (v) m/s max.	Operating temperature °C	Weight g
		Nm max.	Nm max.						
68008.W0141	15	9.8	35280	30	Low	1.0	-10 to +80	80	
68008.W0142	15	9.8	35280	15	Med	1.5	-10 to +80	80	
68008.W0191	20	36.0	22000	27	Low	2.0	-10 to +80	170	
68008.W0192	25	40.0	24200	35	Low	2.0	-10 to +80	180	
68008.W0201	30	44.0	26460	60	V Low	1.2	-10 to +80	185	
68008.W0202	30	44.0	26460	30	Low	1.7	-10 to +80	185	
68008.W0203	30	44.0	26460	15	Med	2.4	-10 to +80	185	
68008.W0204	30	44.0	26460	5	High	4.2	-10 to +80	205	
68008.W0205	30	44.0	26460	3	V High	6.0	-10 to +80	205	
68008.W0211	50	59.0	35280	30	V Low	2.0	-10 to +80	250	
68008.W0213	50	59.0	35280	8	Low	3.8	-10 to +80	250	
68008.W0212	50	59.0	35280	15	Med	2.8	-10 to +80	250	
68008.W0214	50	59.0	35280	5	High	5.0	-10 to +80	250	
68008.W0215	50	59.0	35280	3	V High	6.8	-10 to +80	235	

Order No.	Thread	a	b	c	d	e	f	h	g	i	A/F	k
68008.W0141	M14x1,0	95.2	69.2	12	4	11.0	53.0	19	2.0	5	-	-
68008.W0142	M14x1,0	95.2	69.2	12	4	11.0	53.0	19	2.0	5	-	-
68008.W0191	M20x1,5	129.3	95.0	18	5	15.8	74.5	26	3.8	7	-	-
68008.W0192	M20x1,5	140.4	100.0	18	5	15.8	81.0	26	2.7	7	-	-
68008.W0201	M20x1,5	134.0	85.6	18	5	18.0	48.0	26	21.0	7	18.2	10
68008.W0202	M20x1,5	134.0	85.6	18	5	18.0	48.0	26	21.0	7	18.2	10
68008.W0203	M20x1,5	134.0	85.6	18	5	18.0	48.0	26	21.0	7	18.2	10
68008.W0204	M20x1,5	146.0	97.3	18	5	18.0	48.0	26	32.7	7	18.2	10
68008.W0205	M20x1,5	146.0	97.3	18	5	18.0	48.0	26	32.7	7	18.2	10
68008.W0211	M20x1,5	221.0	156.0	18	5	15.8	136.5	26	4.0	7	18.2	10
68008.W0213	M20x1,5	221.0	156.0	18	5	15.8	136.5	26	4.0	7	18.2	10





# Shock Absorbers, Self Compensating

M14 - M20, non-adjustable

## Shock Absorbers

Order No.	Thread	a	b	c	d	e	f	h	g	i	A/F	k
<b>68008.W0212</b>	M20x1,5	221.0	156.0	18	5	15.8	136.5	26	4.0	7	18.2	10
<b>68008.W0214</b>	M20x1,5	221.0	156.0	18	5	15.8	136.5	26	4.0	7	18.2	10
<b>68008.W0215</b>	M20x1,5	221.0	156.0	18	5	15.8	60.0	26	4.0	7	18.2	10



## 68012

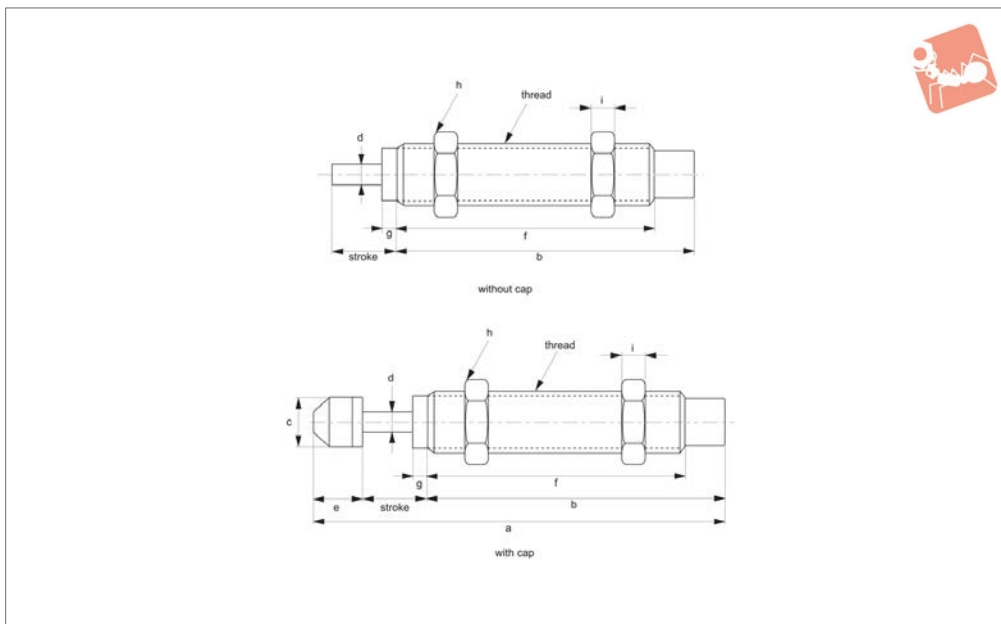

### Material

Outer Tube: STKM11A, hardened and blackened.

Piston Rod: AISI 1045 hardened to HV940°, chrome plated.

Return Spring: DIN GWP.

Muffler Cap: urethane rubber. Seal: nitrile

rubber.

### Technical Notes

Supplied with rubber muffler cap as standard, this is removable - see introductory technical notes for guidance.

### Important Notes

For correct product selection refer to Product Selection Formulae and Calculation pages, and associated Capacity & Selection Charts.

Order No.	With / without cap	Stroke mm	Nm per cycle (Et)		Per hour (ETc)		Effective mass (Me)		Impact speed (v)		Operating temperature °C	Weight g
			Nm max.		Nm max.		kg max.		m/s max.			
68012.W0080	Without	4	0.5		720		3.0		0,3 - 1,0		-10 to +80	4.0
68012.W0081	Without	6	3		7000		6		0,3 - 2,5		-10 to +80	15
68012.W0082	With	6	3		7000		6		0,3 - 2,5		-10 to +80	17
68012.W0101	Without	7	6		12400		12		0,3 - 2,5		-10 to +80	25
68012.W0102	With	7	6		12400		12		0,3 - 3,5		-10 to +80	28
68012.W0121	Without	10	12		22500		22		0,3 - 4,0		-10 to +80	29
68012.W0122	With	10	12		22500		22		0,3 - 4,0		-10 to +80	32
68012.W0141	Without	12	20		33000		40		0,3 - 5,0		-10 to +80	65
68012.W0142	With	12	20		33000		40		0,3 - 5,0		-10 to +80	70
68012.W0143	With	12	14		24000		25.0		0,3 - 5,0		-10 to +80	70
68012.W0201	Without	15	59		38000		120		0,3 - 5,0		-10 to +80	150
68012.W0202	With	15	59		38000		120		0,3 - 5,0		-10 to +80	160
68012.W0251	Without	25	80		60000		180		0,3 - 5,0		-10 to +80	280
68012.W0252	With	25	80		60000		180		0,3 - 5,0		-10 to +80	295
68012.W0271	Without	25	147		72000		270		0,3 - 5,0		-10 to +80	360
68012.W0272	With	25	147		72000		270		0,3 - 5,0		-10 to +80	375

Order No.	Thread	a	b	c	d	e	f	h	g	i	A/F
68012.W0080	M 6x0,75	36.5	28.5	4.5	1.8	4.0	22.5	8.0	1	3.0	-
68012.W0081	M 8x1,0	-	40.6	-	2.9	-	33.6	11.0	2	3	-
68012.W0082	M 8x1,0	55.2	40.6	6.6	2.9	8.6	33.6	11.0	2	3	-
68012.W0101	M10x1,0	-	47.0	-	3.0	-	39.0	12.7	3	3	-
68012.W0102	M10x1,0	62.6	47.0	8.6	3.0	8.6	39.0	12.7	3	3	-
68012.W0121	M12x1,0	-	52.5	-	3.0	-	44.0	14.0	3	4	-
68012.W0122	M12x1,0	71.1	52.5	10.3	3.0	8.6	44.0	14.0	3	4	-
68012.W0141	M14x1,5	-	67.0	-	4.0	-	58.0	19.0	4	5	12.1
68012.W0142	M14x1,5	90.0	67.0	12.0	4.0	11.0	58.0	19.0	4	5	12.1
68012.W0143	M14x1,5	78.8	55.0	12.0	4.0	11.2	46.5	19.0	3.5	5.0	12.1



# Shock Absorbers, Self Compensating

M8 - M27, non-adjustable

# Shock Absorbers

Order No.	Thread	a	b	c	d	e	f	h	g	i	A/F
<b>68012.W0201</b>	M20x1,5	-	73.0	-	6.0	-	62.0	26.0	4	7	18.0
<b>68012.W0202</b>	M20x1,5	103.0	73.0	18.0	6.0	15.0	62.0	26.0	4	7	18.0
<b>68012.W0251</b>	M25x1,5	-	92.0	-	8.0	-	82.0	32.0	-	9	23.0
<b>68012.W0252</b>	M25x1,5	136.0	92.0	22.0	8.0	19.0	82.0	32.0	-	9	23.0
<b>68012.W0271</b>	M27x1,5	-	99.0	-	8.0	-	86.0	36.0	5	6	25.0
<b>68012.W0272</b>	M27x1,5	143.0	99.0	22.0	8.0	19.0	86.0	36.0	5	6	25.0

application examples:

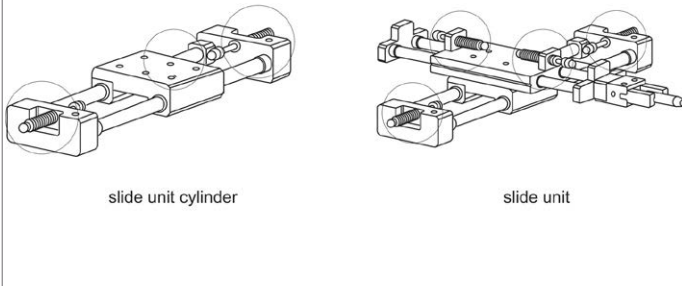



## Shock Absorbers benefits and features

### Why do we need shock absorbers?

Shock Absorbers are widely used in industry where the speed, direction or movement of objects must be changed or stopped. Without suitable methods of control the kinetic energy inherent in many moving objects, which occur in manufacturing, can result in increased machine wear and even machine damage.

Ideally any method of "shock absorption" should provide two key features:

- 1) Bring the moving object to rest quickly, smoothly and without rebounding forces
- 2) In-built reliability and safety

Shock Absorbers are able to quickly convert the kinetic energy of a moving object into heat and to dissipate this into the air, and provide a constant linear deceleration of an object throughout its entire impact stroke, to quickly, smoothly and quietly bring a moving object to rest with the lowest reaction force and in the shortest time. All of these features mean increased manufacturing productivity, extended machine life, and improved efficiency.

### The cost of outdated buffering methods

#### Traditional buffering methods:

- Springs
- Dash Pots
- Air Buffers
- Rubber bumpers

#### Costs associated with outdated cushioning methods:

- Loss of production
- Increased machine wear and tear
- Increased maintenance cost
- Increased vibration and noise pollution
- Varying and inconsistent dampening forces, with non-linear or high peak forces at some point in their stroke.

Traditional buffering methods can only dissipate a small percentage of the kinetic energy of a moving object, the remainder is stored (rather than dissipated) as elastic energy which results in high resistance and rebounding forces toward the end of the impact stroke.

### Benefits of using Wixroyd Shock Absorbers

Wixroyd Shock Absorbers are designed to stop a moving object smoothly and quietly from the beginning to the end of its impact stroke. Their design enables a constant resistance force or linear deceleration throughout the impact stroke, quickly converting the kinetic energy of the moving object into heat which is quickly dissipated into the air. A linear deceleration curve, as achieved by our shock absorbers, brings an object to rest in the shortest time while reducing damaging impact forces.

**Energy Capacity:** Shock absorbers can absorb more energy, without increasing deceleration or reaction forces.

**Stopping Force:** Shock absorbers provide smooth deceleration of parts, which means less machine wear and hence reduced maintenance.

**Stopping time:** Shock absorbers bring moving loads to rest more quickly, increasing productivity.

### Advantages of using Wixroyd Shock Absorbers

- Consistent and reliable dampening force or linear deceleration, throughout entire impact stroke
- Smoother motion and deceleration of moving parts
- Increased productivity
- Extended machine life and improved efficiency
- Simplified application design and build costs
- Reduced maintenance costs
- Improved health and safety, through reduced vibration and noise pollution

### Comparison of shock absorbers vs. other methods

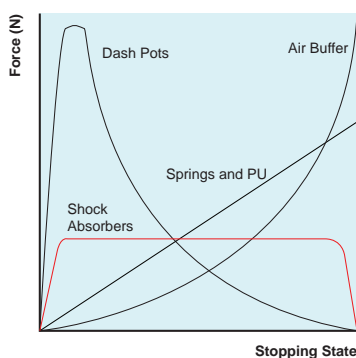

**Dashpots:** produce large peak forces at beginning of impact stroke, abruptly slowing load - however braking force quickly declines.

**Springs & Rubber Buffers:** energy is stored rather than dissipated, resulting in rebounding of the load.

**Air Buffers:** initial braking force is low, but due to the compressibility of air it increases sharply toward later stages of stroke, resulting in inconsistent braking force.

**Shock Absorbers:** designed to stop a moving object smoothly and quietly from beginning to end of its impact stroke. Their design enables constant resistance force or linear deceleration throughout impact stroke, they quickly convert kinetic energy of a moving object into heat which is quickly dissipated into the air.



### Wixroyd Shock Absorbers are available in two primary types



#### Self-compensating

##### Self compensating shock absorber 68001

Our Self-Compensating Shock Absorbers are effective for a stated range of Effective Mass (Me), and are self-compensating within this range - see selection charts. As long as the applications effective mass remains within the given range then no additional adjustment is required for changes in weight, speed or propelling force.

See models: 68001, 68002, 68003, 68004, 68008, 68012

##### Self compensating shock absorber 68002

Each Self-Compensating Shock Absorber is available in three standard max. Impact speed (v-m/s) variations:

- 1 - high impact speed
- 2 - medium impact speed
- 3 - low impact speed

For specific max. impact speed values please refer to the selections charts and the specific product tables.

For hard impact at the start of a stroke it is advisable to choose a high impact speed model, for hard set down at the end of a stroke it is advisable to choose a medium or low impact speed model, or to move up to the next higher bore size



#### Adjustable

##### Adjustable shock absorber 68020

Set collar to 0 at initial installation

After a few cycles adjust collar setting to suit application

Adjustable Shock Absorbers have an adjustment collar at their base (with a scale of 0-9), which enables adjustment of the Shock Absorber's optimum deceleration to suit the application.

After initial installation, the Shock Absorber should be cycled a number of times to settle, and then the adjustable collar turned to the desired position for the application.

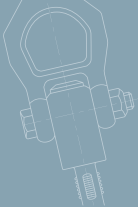

Inside a Wixroyd Shock Absorber

Shock absorber design

The design of Wixroyd Shock Absorbers is beautifully simple and beautifully effective. Made from high quality materials and components, they provide the highest performance and reliability.

SHOCK ABSORBERS

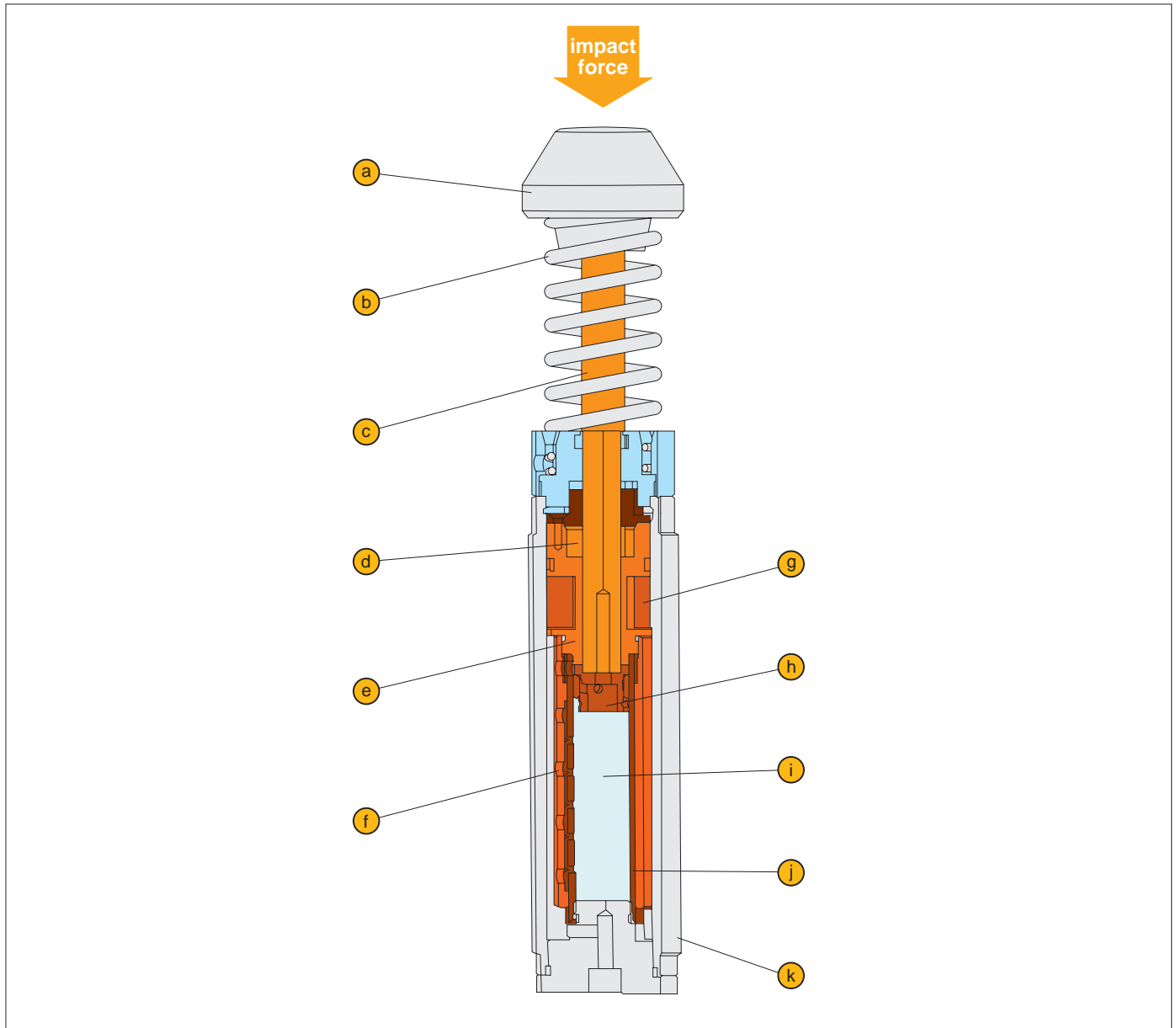

- a** Impact Cap
- b** Return Spring; DIN GWP (external and internal models avai.)
- c** Piston Rod; AISI 1045, hardened to HV940°, chrome plated
- d** Seal
- e** Bearing
- f** Orifices
- g** Accumulator; neoprene rubber
- h** Check Valve
- i** Fluid
- j** Inner Tube
- k** Outer Tube; STKM11A, hardened and blackened

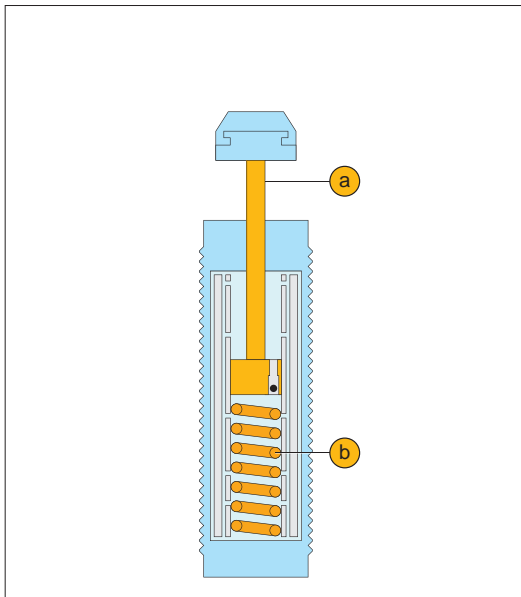

### At rest

1) Shock Absorber at rest, piston rod (1), fully extended through force exerted on it by return spring (2).

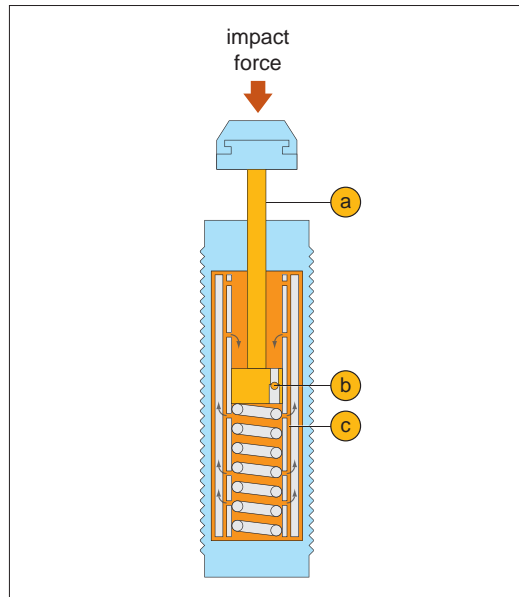

### Initial impact

2) Moving load impacts piston (1), which moves into shock absorber body increasing pressure in chamber.  
3) Piston rod check valve closes (2). Hydraulic oil behind the piston head is initially able to escape/vent into the accumulator (3).

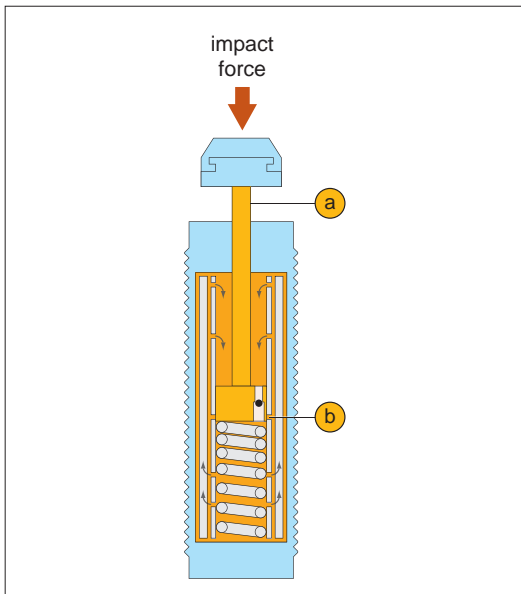

### Continued impact and linear deceleration

4) As load on piston rod (1) increases, the rod continues to move back into the inner tube, as it does so the number of available metering orifices (2) through which the hydraulic oil is able to escape reduces - hence the velocity of the moving load continues to decelerate.

5) The number and position of the orifices are such that the pressure in the inner tube remains constant throughout the entire impact stroke - providing constant linear deceleration. (Number of metering orifices decreases proportionally through length of piston rod.)

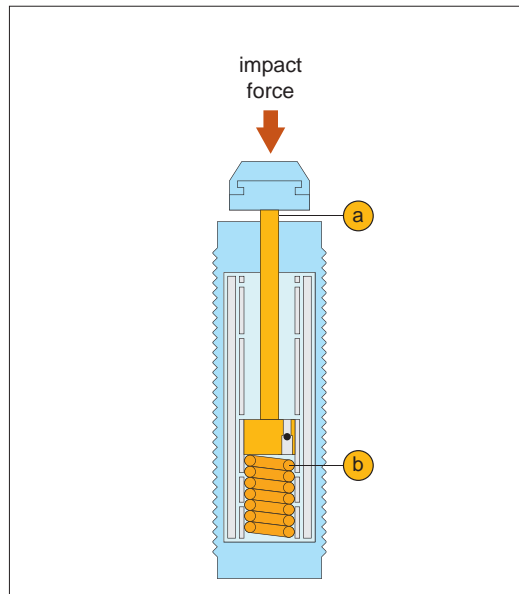

### Load brought to rest

6) The moving load is brought to a smooth and quiet stop.  
7) When the load is removed the return spring (2) pushes the piston (1), back to its original resting position, ready for the next cycle.

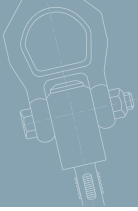

## Optional extras

### Stop collars

We advise the use of external mechanical stops with all of our Shock Absorbers, typically within 1 to 0.5 mm from the end of the stroke. Alternatively, we have a range of stop collars available which can be mounted directly to the shock absorber body (see our part 68030). Stop Collars are available for our M8 to M36 threaded models, they can be used both to adjust stroke and also to fix the end position of the load.

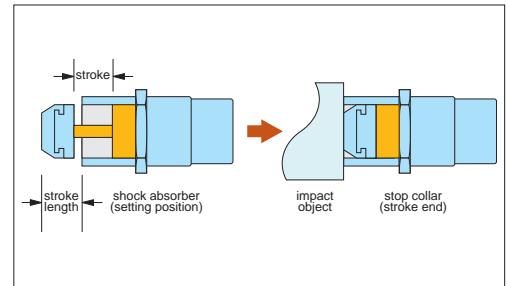

### Flange mounting adaptors

Basic mounting of shock absorbers is through the use of its threaded body, and lock nuts supplied. Alternatively Shock Absorbers can be flange mounted, please see our available flange mounting adaptors part 68032 for our M36 and M42 threaded models.

### Muffler caps

Shock Absorbers are supplied with muffler caps as standard. Muffler caps can be removed from the Shock Absorber Piston by heating them with a lighter and pulling away using a pair of pliers.

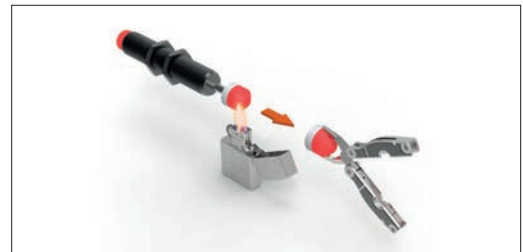

## Application examples

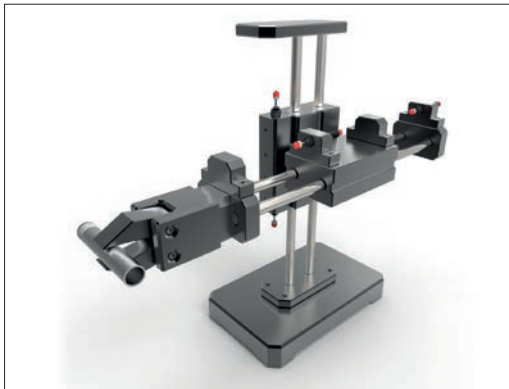

Pick and place robots

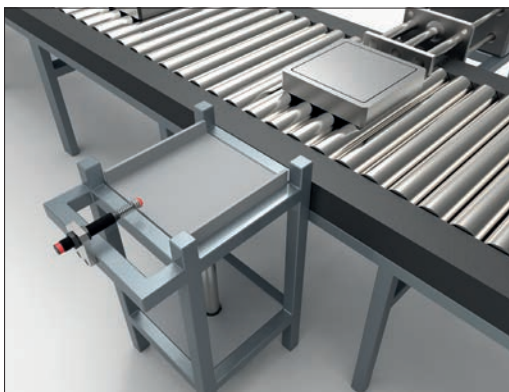
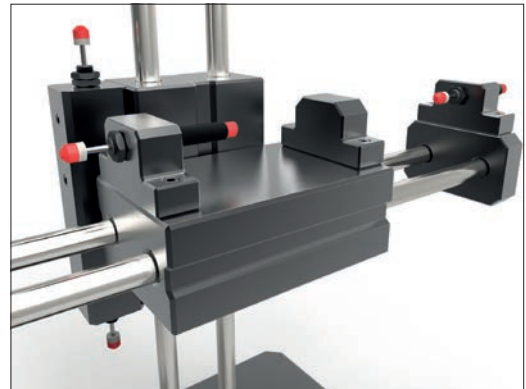

Pick and place machines

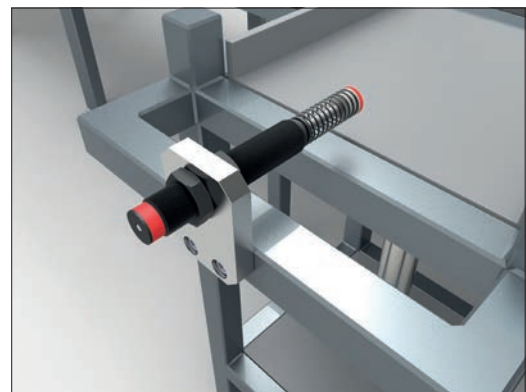



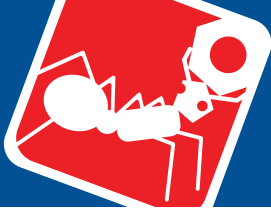

### How to select your Wixroyd Shock Absorber

- |  |  |
|--|--|
| 1) Direction of movement - horizontal, free fall or rotary | 4) Impact velocity of load                                     |
| 2) Total weight of impacting object                        | 5) Number of cycles/impact per hour                            |
| 3) Propelling force - if present                           | 6) Number of shock absorbers in application (only if parallel) |

**Firstly consider the following:**

- |   |  |
|---|--|
| 1) Mass to be decelerated (weight) ..... m (kg) | 4) Number of impact cycles per hour... C (/hr) |
| 2) Impact velocity at shock absorber ..v (m/s)  | 5) Desired shock absorber stroke ..... S (m)   |
| 3) Propelling or driving force..... F (N)       |  |

**Secondly, ascertain the following from your application**

ET (Nm) Maximum energy absorbed per cycle  
 ETC (Nm/hr) Maximum energy absorbed per hour  
 Me (Kg) Effective mass

**Thirdly, derive value for the following within your application**

Formulae on the following pages will allow you to derive these values for the most appropriate set-up of your application.

Using the values derived from you calculations, refer to our selection charts and identify the most suitable Wixroyd Shock Absorber for your application.

**Finally, refer to our selection charts**

### Mounting and installation information

1. Please install a 1 to 0.5 mm mechanical stop or stop collar before the end of the impact stroke and do not drive shock absorbers into their final position under full load. See the range of Stop Collars part 68030, which can be easily mounted on to shock absorbers to protect shock absorber pistons from bottoming out and can also be used to adjust the final stroke.
2. Reusing is prohibited after dismantling. Do not paint the piston rod or threaded body. This both inhibits movement of the piston and can interfere with effective heat dissipation.
3. Install shock absorbers as close to the moving object's centre as possible.
4. If installing shock absorbers in sheet metal, please ensure sheet metal is robust enough.
5. When installing two or more shock absorbers in parallel, please ensure that they have the same stroke.

### Product selection calculation

- |   |   |
|---|---|
| 1) Kinetic energy: ..... $E_k = mv^2/2$   | 5) Maximum shock force (approximate): ..... $F_m = 1.2 E_T/S$                   |
| 2) Drive energy: ..... $E_D = F \cdot S$  | 6) Propelling force generated by electric motors: ..... $F = 3000 \text{ kW}/v$ |
| 3) Free fall velocity: ..... $v = \sqrt{2g \cdot h}$                                | 7) Total energy absorbed per hour: ..... $E_{TC} = E_T \cdot C$                 |
| 4) Pneumatic or hydraulic cylinder driving forces: ..... $F = 0.00785 \text{ Pd}^2$ |   |

**Some useful calculation formulae**

$\mu$	-	coefficient of friction	$E_{TC}$	(Nm)	total energy per hour	$M_e$	(kg)	effective mass
$\alpha$	(rad)	angle of incline	F	(N)	propelling force	P	(Bar)	operation pressure
$\theta$	(rad)	side load of angle	$F_m$	(N)	maximum shock force	R	(m)	radius
$\omega$	(rad/s)	angular velocity	g	(m/s <sup>2</sup> )	acceleration due to gravity (9.81m/s <sup>2</sup> )	$R_s$	(m)	shock absorber mounting distance from rotation center
A	(m)	width	h	(m)	height	S	(m)	stroke
B	(m)	thickness	I	(Nm/s <sup>2</sup> )	moment of inertia	T	(Nm)	driving torque
C	(/hr)	impact cycles per hour	-	-	arresting torque factor for motors (normally 2.5)	t	(s)	decelartion time
d	(mm)	cylinder bore diameter	HM	-	arresting torque factor for motors (normally 2.5)	v	(m/s)	velocity of impact mass
$E_D$	(Nm)	drive energy per cycle	kW	(kW)	electric motor power	$v_s$	(m/s)	impact velocity at shock absorber
$E_k$	(Nm)	kinetic energy per cycle	m	(kg)	mass to be decelerated			
$E_T$	(Nm)	total energy per cycle						

**Key to formulae symbols used**

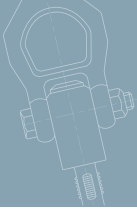

### 1) Horizontal moving mass - without propelling force

m = 300kg  
v = 1,0m/s  
S = 0,04m  
C = 300/hr

$$E_k = \frac{mv^2}{2} = \frac{300 \cdot 1,0^2}{2} = 150\text{Nm}$$

$$E_T = E_k = 150\text{Nm}$$

$$E_{TC} = E_T \cdot C = 150 \cdot 300 = 45000\text{Nm/hr}$$

$$M_e = \frac{2E_T}{v^2} = \frac{2 \cdot 150}{1,0^2} = 300\text{kg}$$

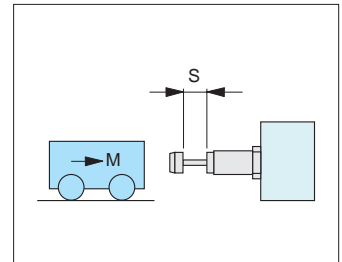

Selection from capacity chart: 68024.W0362 is suitable

### 2) Horizontal moving mass - with propelling force

m = 300kg  
v = 1,2m/s  
S = 0,05m  
P = 40N/cm<sup>2</sup>  
d = 100mm  
C = 300/hr

$$E_k = \frac{mv^2}{2} = \frac{300 \cdot 1,2^2}{2} = 216\text{Nm}$$

$$E_D = F \cdot S = 0,00785Pd^2 \cdot S = 0,00785 \cdot 40 \cdot 100^2 \cdot 0,05 = 157\text{Nm}$$

$$E_T = E_k + E_D = 216 + 157 = 373\text{Nm}$$

$$E_{TC} = E_T \cdot C = 373 \cdot 300 = 111900\text{Nm/hr}$$

$$M_e = \frac{2E_T}{v^2} = \frac{2 \cdot 373}{1,2^2} = 518\text{kg}$$

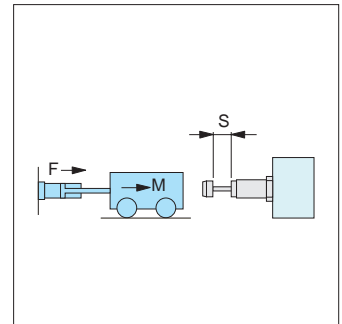

Selection from capacity chart: 68024.W0422 is suitable

### 3) Horizontal moving mass - motor driven

m = 400kg  
v = 1,0m/s  
kW = 1,5kW  
HM = 2,5  
S = 0,075m  
C = 60/hr

$$E_k = \frac{mv^2}{2} = \frac{400 \cdot 1,0^2}{2} = 200\text{Nm}$$

$$E_D = F \cdot S = \frac{kW \cdot HM}{v} \cdot S = \frac{1500 \cdot 2,5}{1,0} \cdot 0,075 = 281\text{Nm}$$

$$E_T = E_k + E_D = 200 + 281 = 481\text{Nm}$$

$$E_{TC} = E_T \cdot C = 481 \cdot 60 = 25860\text{Nm/hr}$$

$$M_e = \frac{2E_T}{v^2} = \frac{2 \cdot 481}{1,0^2} = 962\text{kg}$$

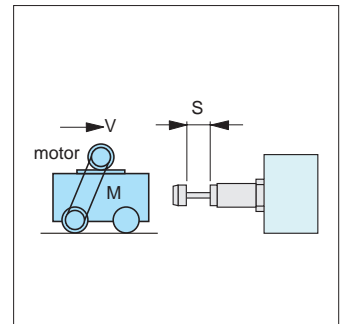

Selection from capacity chart: 68024.W0423 is suitable

### 4) Horizontal moving mass - driven rollers

m = 150kg  
v = 0,5m/s  
μ = 0,25  
S = 0,02m  
C = 120/hr

$$E_k = \frac{mv^2}{2} = \frac{150 \cdot 0,5^2}{2} = 18,75\text{Nm}$$

$$E_D = F \cdot S = mg\mu \cdot S = 150 \cdot 9,81 \cdot 0,25 \cdot 0,02 = 7,35\text{Nm}$$

$$E_T = E_k + E_D = 18,75 + 7,35 = 26,1\text{Nm}$$

$$E_{TC} = E_T \cdot C = 26,1 \cdot 120 = 3132\text{Nm/hr}$$

$$M_e = \frac{2E_T}{v^2} = \frac{2 \cdot 26,1}{0,5^2} = 208,8\text{kg}$$

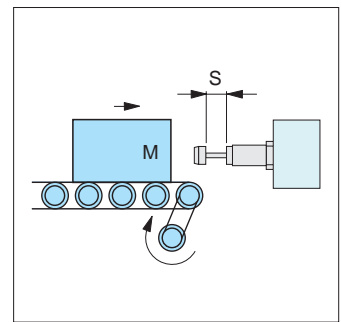

Selection from capacity chart: 68002.W0203 is suitable

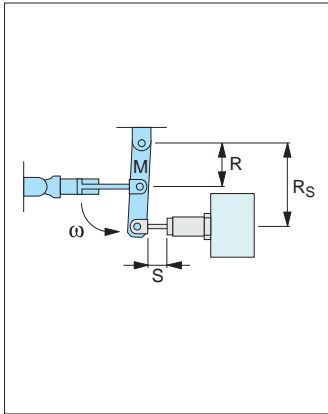

$$E_k = \frac{I \cdot \omega^2}{2} = \frac{216 \cdot 3^2}{2} = 972 \text{ Nm}$$

$$F = \frac{0,0785 \cdot D^2 \cdot P \cdot R}{R_s} = \frac{0,0785 \cdot 80^2 \cdot 5 \cdot 0,6}{0,9} = 1674,7 \text{ Nm}$$

$$E_D = F \cdot S = 1674,7 \cdot 0,05 = 83,7 \text{ Nm}$$

$$E_T = E_k + E_D = 972 + 83,7 = 1055,7 \text{ Nm}$$

$$E_{TC} = E_T \cdot C = 1055,7 \cdot 150 = 158355 \text{ Nm/hr}$$

$$v = R_s \cdot \omega = 0,6 \cdot 3 = 1,8 \text{ m/s}$$

$$M_e = \frac{2E_T}{v^2} = \frac{2 \cdot 1055,7}{1,8^2} = 651,2 \text{ kg}$$

## 5) Swinging arm - with propelling force (universal weight distribution)

P = 5bar  
m = 600kg  
ω = 3rad/s  
R = 0,6m  
R<sub>s</sub> = 0,9m  
d = 80mm  
C = 150/hr  
I = 216Nm/s<sup>2</sup>

Selection from capacity chart: 68002.W0203 is suitable

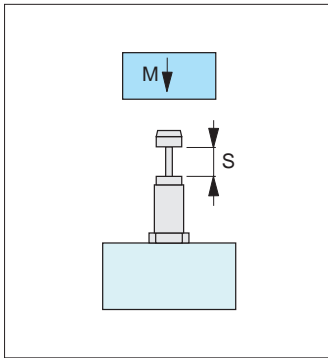

$$v = \sqrt{2g \cdot h} = \sqrt{2 \cdot 9,81 \cdot 0,4} = 2,8 \text{ m/s}$$

$$E_k = \frac{mv^2}{2} = \frac{40 \cdot 2,8^2}{2} = 157 \text{ Nm}$$

$$E_D = F \cdot S = mg \cdot h = 40 \cdot 9,81 \cdot 0,06 = 23,5 \text{ Nm}$$

$$E_T = E_k + E_D = 157 + 23,5 = 180,5 \text{ Nm}$$

$$E_{TC} = E_T \cdot C = 180,5 \cdot 200 = 36100 \text{ Nm/hr}$$

$$M_e = \frac{2E_T}{v^2} = \frac{2 \cdot 180,5}{2,8^2} = 46 \text{ kg}$$

## 6) Vertical moving mass - free falling

m = 40kg  
h = 0,4m  
S = 0,06m  
C = 200/hr

Selection from capacity chart: 68003.W0361 is suitable

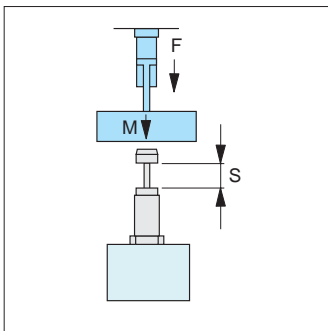

$$E_k = \frac{mv^2}{2} = \frac{40 \cdot 1,0^2}{2} = 20 \text{ Nm}$$

$$E_D = F \cdot S = (mg + 0,0785Pd^2) \cdot S = (40 \cdot 9,81 + 0,0785 \cdot 5 \cdot 50^2) \cdot 0,025 = 33,5 \text{ Nm}$$

$$E_T = E_k + E_D = 20 + 33,5 = 55,5 \text{ Nm}$$

$$E_{TC} = E_T \cdot C = 55,5 \cdot 200 = 11100 \text{ Nm/hr}$$

$$M_e = \frac{2E_T}{v^2} = \frac{2 \cdot 55,5}{1,0^2} = 111 \text{ kg}$$

## 7) Vertical moving mass - with propelling force

m = 40kg  
h = 0,3m  
S = 0,025m  
P = 5bar  
d = 50mm  
C = 200/hr  
v = 1,0m/s

Selection from capacity chart: 68024.W0252 is suitable

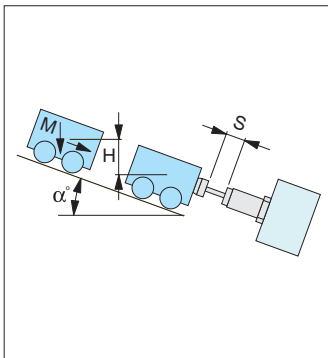

$$v = \sqrt{2g \cdot h} = \sqrt{2 \cdot 9,81 \cdot 0,3} = 2,43 \text{ m/s}$$

$$E_k = \frac{mv^2}{2} = \frac{150 \cdot 2,43^2}{2} = 443 \text{ Nm}$$

$$E_D = F \cdot S = m \cdot g \cdot S \cdot \sin \alpha = 150 \cdot 9,81 \cdot 0,075 \cdot \sin 30^\circ = 55,2 \text{ Nm}$$

$$E_T = E_k + E_D = 433 + 55,2 = 498,2 \text{ Nm}$$

$$E_{TC} = E_T \cdot C = 498,2 \cdot 200 = 99640 \text{ Nm/hr}$$

$$M_e = \frac{2E_T}{v^2} = \frac{2 \cdot 498,2}{2,43^2} = 168,7 \text{ kg}$$

## 8) Free moving mass - on inclined plane

m = 150kg  
h = 0,3m  
α = 30°  
S = 0,075m  
C = 200/hr

Selection from capacity chart: 68024.W0423 is suitable

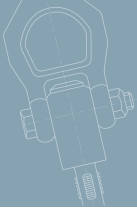

## 9) Horizontal rotating door

- m = 20kg
- $\omega = 2,0\text{rad/s}$
- T = 20Nm
- R<sub>S</sub> = 0,8m
- A = 1,0m
- B = 0,05m
- S = 0,016m
- C = 100/hr

$$I = \frac{m(4A^2 + B^2)}{12} = \frac{20(4 \cdot 1,0^2 + 0,05^2)}{12} = 6,67\text{kg} \cdot \text{m}^2$$

$$E_k = \frac{I^2}{2} = \frac{6,67 \cdot 2,0^2}{2} = 13,34\text{Nm}$$

$$= \frac{S}{R_S} = \frac{0,04}{0,8} = 0,05\text{rad}$$

$$E_D = T \cdot = 20 \cdot 0,5 = 1,0\text{Nm}$$

$$E_T = E_k + E_D = 13,34 + 1,0 = 14,34\text{Nm}$$

$$E_{TC} = E_T \cdot C = 14,34 \cdot 100 = 1434\text{Nm/hr}$$

$$v = \cdot R_S = 2,0 \cdot 0,8 = 1,6\text{m/s}$$

$$M_e = \frac{2E_T}{v^2} = \frac{2 \cdot 14,34}{1,6^2} = 11,2\text{kg}$$

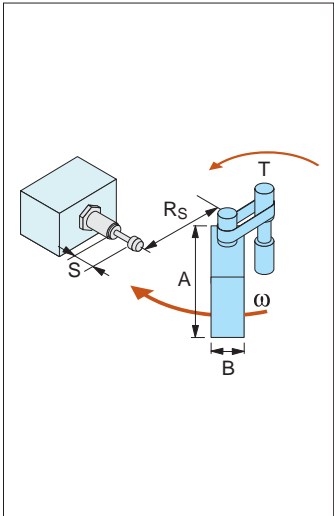

Selection from capacity chart: 68002.W0203 is suitable

## 10) Horizontal rotating mass - with torque

- m = 40kg
- A = 0,5m
- B = 0,05m
- $\omega = 2,0\text{rad/s}$
- T = 10Nm
- R<sub>S</sub> = 0,4m
- S = 0,05m
- C = 50/hr

$$I = \frac{m(4A^2 + B^2)}{12} = \frac{40(4 \cdot 0,5^2 + 0,05^2)}{12} = 3,36\text{kg} \cdot \text{m}^2$$

$$E_k = \frac{I^2}{2} = \frac{3,36 \cdot 2,0^2}{2} = 6,8\text{Nm}$$

$$= \frac{S}{R_S} = \frac{0,05}{0,4} = 0,125\text{rad}$$

$$E_D = T \cdot = 10 \cdot 0,125 = 1,25\text{Nm}$$

$$E_T = E_k + E_D = 6,8 + 1,25 = 8,05\text{Nm}$$

$$E_{TC} = E_T \cdot C = 8,05 \cdot 50 = 402,5\text{Nm/hr}$$

$$v = \cdot R_S = 2,0 \cdot 0,4 = 0,8\text{m/s}$$

$$M_e = \frac{2E_T}{v^2} = \frac{2 \cdot 8,05}{0,8^2} = 25,15\text{kg}$$

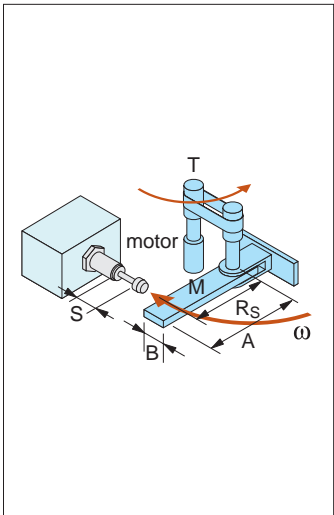

Selection from capacity chart: 68003.W0361 is suitable

## 11) Rotary index table - with propelling force

- m = 200kg
- $\omega = 1,0\text{rad/s}$
- T = 100Nm
- R = 0,5m
- R<sub>S</sub> = 0,4m
- S = 0,04m
- C = 100/hr

$$I = \frac{mR^2}{2} = \frac{200 \cdot 0,5^2}{2} = 25\text{kg} \cdot \text{m}^2$$

$$E_k = \frac{I^2}{2} = \frac{25 \cdot 1,0^2}{2} = 12,5\text{Nm}$$

$$= \frac{S}{R_S} = \frac{0,04}{0,4} = 0,1\text{rad}$$

$$E_D = T \cdot = 100 \cdot 0,1 = 10\text{Nm}$$

$$E_T = E_k + E_D = 12,5 + 10 = 22,5\text{Nm}$$

$$E_{TC} = E_T \cdot C = 22,5 \cdot 50 = 1125\text{Nm/hr}$$

$$v = \cdot R_S = 1,0 \cdot 0,4 = 0,4\text{m/s}$$

$$M_e = \frac{2E_T}{v^2} = \frac{2 \cdot 22,5}{0,4^2} = 281\text{kg}$$

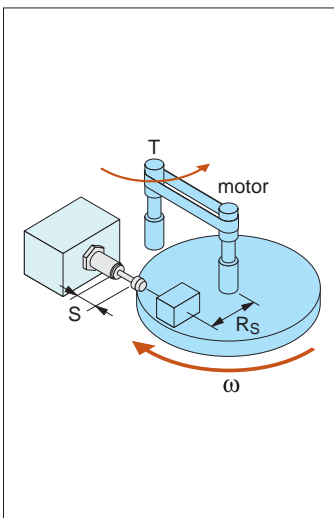

Selection from capacity chart: 68024.W0255 is suitable



### 68001 - shock absorbers - self compensating

Order Number	Stroke (mm)	Thread (mm)	Max. Energy per cycle Nm (ET)	Max. Energy per hour Nm/hr (ETC)	Max. Effective Mass Kg (Me)	Max. Impact Speed m/s (v)	Operating temp. (°C)	Avai. w/o cap	Avai. with cap	Flange Avai.	Stop Collar Avai.	Weight (g)
68001.W0081	6	M 8 x 1,0	2	8,800	0,5	2,0	-10~+80	•	•	-	•	11
68001.W0082	6	M 8 x 1,0	2	8,800	2,0	1,0	-10~+80	•	•	-	•	11
68001.W0083	6	M 8 x 1,0	2	8,800	6,0	0,5	-10~+80	•	•	-	•	11
68001.W0101	5	M10 x 1,0	3	10,800	1,0	3,0	-10~+80	•	•	-	•	14
68001.W0102	5	M10 x 1,0	3	10,800	3,0	1,5	-10~+80	•	•	-	•	14
68001.W0103	5	M10 x 1,0	3	10,800	7,0	0,8	-10~+80	•	•	-	•	14
68001.W0104	8	M10 x 1,0	4	15,200	2,0	3,0	-10~+80	•	•	-	•	20
68001.W0105	8	M10 x 1,0	4	15,200	4,0	1,5	-10~+80	•	•	-	•	20
68001.W0106	8	M10 x 1,0	4	15,200	9,0	0,8	-10~+80	•	•	-	•	20
68001.W0107	10	M10 x 0,75	4	10,800	1,0	3,0	-10~+80	•	•	-	•	20
68001.W0108	10	M10 x 0,75	4	10,800	2,0	1,0	-10~+80	•	•	-	•	20
68001.W0109	10	M10 x 0,75	4	10,800	3,0	0,5	-10~+80	•	•	-	•	20
68001.W0121	10	M12 x 1,0	5	17,640	5,0	3,0	-10~+80	•	•	-	•	32
68001.W0122	10	M12 x 1,0	5	17,640	10,0	1,5	-10~+80	•	•	-	•	32
68001.W0123	10	M12 x 1,0	5	17,640	30,0	0,8	-10~+80	•	•	-	•	32

### 68002, 68004 - shock absorbers - self compensating

Order Number	Stroke (mm)	Thread (mm)	Max. Energy per cycle Nm (ET)	Max. Energy per hour Nm/hr (ETC)	Max Effective Mass Kg (Me)	Max. Impact Speed m/s (v)	Operating temp. (°C)	Avai. w/o cap	Avai. with cap	Flange Avai.	Stop Collar Avai.	Weight (g)
68002.W0141	12	M14 x 1,5	15	30,000	8	3,0	-10~+80	•	•	-	•	80
68002.W0142	12	M14 x 1,5	15	30,000	50	1,5	-10~+80	•	•	-	•	80
68002.W0143	12	M14 x 1,5	15	30,000	100	0,8	-10~+80	•	•	-	•	80
68002.W0147	16	M14 x 1,5	20	35,000	10	3,0	-10~+80	•	•	-	•	80
68002.W0148	16	M14 x 1,5	20	35,000	70	1,0	-10~+80	•	•	-	•	80
68002.W0149	16	M14 x 1,5	20	35,000	150	0,5	-10~+80	•	•	-	•	80
68002.W0198	20	M14 x 1,5	20	35,000	10	3,0	-10~+80	•	•	-	•	80
68002.W0199	20	M14 x 1,5	20	35,000	70	1,0	-10~+80	•	•	-	•	80
68002.W0200	20	M14 x 1,5	20	35,000	150	0,5	-10~+80	•	•	-	•	80
68002.W0201	20	M20 x 1,5	40	40,000	30	3,5	-10~+80	•	•	-	•	215
68002.W0202	20	M20 x 1,5	40	40,000	200	2,0	-10~+80	•	•	-	•	215
68002.W0203	20	M20 x 1,5	40	40,000	700	1,0	-10~+80	•	•	-	•	215
68002.W0204	30	M20 x 1,5	50	48,000	30	3,5	-10~+80	•	•	-	•	220
68002.W0205	30	M20 x 1,5	50	48,000	200	2,0	-10~+80	•	•	-	•	220
68002.W0206	30	M20 x 1,5	50	48,000	700	1,0	-10~+80	•	•	-	•	220
68002.W0207	50	M20 x 1,5	60	60,000	60	3,5	-10~+80	-	•	-	•	300
68002.W0208	50	M20 x 1,5	60	60,000	400	2,0	-10~+80	-	•	-	•	300
68002.W0209	50	M20 x 1,5	60	60,000	1,200	1,0	-10~+80	-	•	-	•	300
68004.W0201	30	M20 x 1,5	45	55,000	40	3,5	-10~+80	-	•	-	•	220
68004.W0202	30	M20 x 1,5	45	55,000	300	2,0	-10~+80	-	•	-	•	220
68004.W0203	30	M20 x 1,5	45	55,000	900	1,0	-10~+80	-	•	-	•	220
68004.W0204	35	M20 x 1,5	52	63,000	40	3,5	-10~+80	-	•	-	•	210
68004.W0205	35	M20 x 1,5	52	63,000	200	2,0	-10~+80	-	•	-	•	210
68004.W0206	35	M20 x 1,5	52	63,000	650	1,0	-10~+80	-	•	-	•	210
68004.W0207	50	M20 x 1,5	60	68,000	60	3,5	-10~+80	-	•	-	•	470
68004.W0208	50	M20 x 1,5	60	68,000	210	2,0	-10~+80	-	•	-	•	470
68004.W0209	50	M20 x 1,5	60	68,000	480	1,0	-10~+80	-	•	-	•	470

ov-W68001-A-T-W68032-A-T-j-rmh- Updated - 31-10-2022

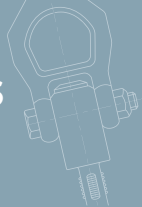

## 68003 - shock absorbers - self compensating

Order Number	Stroke (mm)	Thread (mm)	Max. Energy per cycle Nm (ET)	Max. Energy per hour Nm/hr (ETC)	Max Effective Mass Kg (Me)	Max. Impact Speed m/s (v)	Operating temp. (°C)	Avai. w/o cap	Avai. with cap	Flange Avai.	Stop Collar Avai.	Weight (g)
68003.W0251	25	M25 x 1,5	80	54,000	200	4,0	-10~+80	•	•	-	•	330
68003.W0252	25	M25 x 1,5	80	54,000	800	2,5	-10~+80	•	•	-	•	330
68003.W0253	25	M25 x 1,5	80	54,000	1,500	1,0	-10~+80	•	•	-	•	330
68003.W0254	40	M25 x 1,5	120	75,000	300	4,0	-10~+80	-	•	-	•	430
68003.W0255	40	M25 x 1,5	120	75,000	1,200	2,5	-10~+80	-	•	-	•	430
68003.W0256	40	M25 x 1,5	120	75,000	2,000	1,0	-10~+80	-	•	-	•	430
68003.W0257	50	M25 x 1,5	98	90,000	15	4,0	-10~+80	•	•	-	•	435
68003.W0258	50	M25 x 1,5	98	90,000	40	2,5	-10~+80	•	•	-	•	435
68003.W0259	50	M25 x 1,5	98	90,000	160	1,0	-10~+80	•	•	-	•	435
68003.W0261	80	M25 x 1,5	150	120,000	20	4,0	-10~+80	•	•	-	•	535
68003.W0262	80	M25 x 1,5	150	120,000	50	2,5	-10~+80	•	•	-	•	535
68003.W0263	80	M25 x 1,5	150	120,000	200	1,0	-10~+80	•	•	-	•	535
68003.W0361	60	M36 x 1,5	250	120,000	400	4,0	-10~+80	-	•	•	•	1030
68003.W0362	60	M36 x 1,5	250	120,000	1,500	2,5	-10~+80	-	•	•	•	1030
68003.W0363	60	M36 x 1,5	250	120,000	2,400	1,0	-10~+80	-	•	•	•	1030

## 68005 - shock absorbers - self compensating

Order Number	Stroke (mm)	Thread (mm)	Max. Energy per cycle Nm (ET)	Max. Energy per hour Nm/hr (ETC)	Max Effective Mass Kg (Me)	Max. Impact Speed m/s (v)	Operating temp. (°C)	Avai. w/o cap	Avai. with cap	Flange Avai.	Stop Collar Avai.	Weight (g)
68005.W0301	25	M30 x 1,5	180	60,000	300	3,0	-10~+80	-	•	-	•	950
68005.W0302	25	M30 x 1,5	180	60,000	700	2,0	-10~+80	-	•	-	•	950
68005.W0303	25	M30 x 1,5	180	60,000	1,300	1,0	-10~+80	-	•	-	•	950

## 68008 - shock absorbers - self compensating

Order Number	Stroke (mm)	Thread (mm)	Max. Energy per cycle Nm (ET)	Max. Energy per hour Nm/hr (ETC)	Max Effective Mass Kg (Me)	Max. Impact Speed m/s (v)	Operating temp. (°C)	Avai. w/o cap	Avai. with cap	Flange Avai.	Stop Collar Avai.	Weight (g)
68008.W0141	15	M14 x 1,0	9,8	35,280	30	1,0	-10~+80	-	•	-	•	80
68008.W0142	15	M14 x 1,0	9,8	35,280	15	1,5	-10~+80	-	•	-	•	80
68008.W0191	20	M20 x 1,5	36	22,000	27	2	-10~+80	•	•	-	•	170
68008.W0192	25	M20 x 1,5	40	24,200	35	2	-10~+80	•	•	-	•	180
68008.W0201	30	M20 x 1,5	44	26,460	60	1,2	-10~+80	-	•	-	•	185
68008.W0202	30	M20 x 1,5	44	26,460	30	1,7	-10~+80	-	•	-	•	185
68008.W0203	30	M20 x 1,5	44	26,460	15	2,4	-10~+80	-	•	-	•	185
68008.W0204	30	M20 x 1,5	44	26,460	5	4,2	-10~+80	-	•	-	•	205
68008.W0205	30	M20 x 1,5	44	26,460	3	6,0	-10~+80	-	•	-	•	205
68008.W0211	50	M20 x 1,5	59	35,280	30	2,0	-10~+80	-	•	-	•	250
68008.W0212	50	M20 x 1,5	59	35,280	15	2,8	-10~+80	-	•	-	•	250
68008.W0213	50	M20 x 1,5	59	35,280	8	3,8	-10~+80	-	•	-	•	250
68008.W0214	50	M20 x 1,5	59	35,280	5	5,0	-10~+80	-	•	-	•	250
68008.W0215	50	M20 x 1,5	59	35,280	3	6,8	-10~+80	-	•	-	•	235

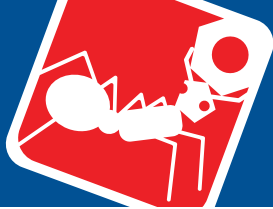

# Wixroyd Shock Absorbers

## capacity and selection charts



# Materials Handling

### 68012 - shock absorbers - self compensating

Order Number	Stroke (mm)	Thread (mm)	Max. Energy per cycle Nm (ET)	Max. Energy per hour Nm/hr (ETC)	Max Effective Mass Kg (Me)	Max. Impact Speed m/s (v)	Operating temp. (°C)	Avai. w/o cap	Avai. with cap	Flange Avai.	Stop Collar Avai.	Weight (g)
68012.W0081/82	6	M14 x 1,0	3	7,000	6	2,5	-10~+80	•	•	-	•	17
68012.W0101/102	7	M14 x 1,0	6	12,400	12	3,5	-10~+80	•	•	-	•	28
68012.W0121/122	10	M20 x 1,5	12	22,500	22	4,0	-10~+80	•	•	-	•	32
68012.W0141/142	12	M20 x 1,5	20	33,000	40	5,0	-10~+80	•	•	-	•	70
68012.W0201/202	15	M20 x 1,5	59	38,000	120	5,0	-10~+80	•	•	-	•	160
68012.W0251/252	25	M20 x 1,5	80	60,000	180	5,0	-10~+80	•	•	-	•	295
68012.W0271/272	25	M20 x 1,5	147	72,000	270	5,0	-10~+80	•	•	-	•	375

### 68020, 68024 - shock absorbers - adjustable

Order Number	Stroke (mm)	Thread (mm)	Max. Energy per cycle Nm (ET)	Max. Energy per hour Nm/hr (ETC)	Max Effective Mass Kg (Me)	Max. Impact Speed m/s (v)	Operating temp. (°C)	Avai. w/o cap	Avai. with cap	Flange Avai.	Stop Collar Avai.	Weight (g)
68020.W0141	10	M14 x 1,5	20	25,000	80	3,0	-10~+80	•	•	-	•	90
68020.W0142	10	M14 x 1,5	20	25,000	80	3,0	-10~+80	•	•	-	•	90
68020.W0199	16	M20 x 1,5	25	28,500	200	3,5	-10~+80	•	•	-	•	222
68020.W0200	16	M20 x 1,5	25	28,500	200	3,5	-10~+80	•	•	-	•	230
68020.W0203	25	M20 x 1,5	39	30,000	200	3,5	-10~+80	•	•	-	•	230
68020.W0204	25	M20 x 1,5	39	30,000	312	3,5	-10~+80	•	•	-	•	240
68024.W0251	25	M25 x 1,5	85	54,000	400	3,5	-10~+80	•	•	-	•	335
68024.W0252	25	M25 x 1,5	85	54,000	400	3,5	-10~+80	•	•	-	•	350
68024.W0253	30	M25 x 1,5	95	60,000	480	3,5	-10~+80	•	•	-	•	340
68024.W0254	30	M25 x 1,5	95	60,000	480	3,5	-10~+80	•	•	-	•	365
68024.W0255	40	M25 x 1,5	100	80,000	700	3,5	-10~+80	-	•	-	•	455
68024.W0256	50	M25 x 1,5	98	90,000	720	4,0	-10~+80	•	•	-	•	455
68024.W0257	80	M25 x 1,5	150	120,000	800	4,0	-10~+80	•	•	-	•	585
68024.W0361	25	M36 x 1,5	150	81,000	1400	3,0	-10~+80	-	•	•	•	955
68024.W0362	50	M36 x 1,5	300	100,000	1400	3,0	-10~+80	-	•	•	•	1100
68024.W0421	25	M42 x 1,5	260	125,000	3000	3,5	-10~+80	-	•	•	-	1280
68024.W0422	50	M42 x 1,5	500	150,000	4000	4,5	-10~+80	-	•	•	-	1490
68024.W0423	75	M42 x 1,5	750	180,000	6000	4,5	-10~+80	-	•	•	-	1710