

62140

PRECISION LEVELLING ADJUSTERS

Material

Steel (type 42 CrMo4 V, 1.7225) zinc plated or stainless steel A1 (A4 on request).

Technical Notes

Compensates for non-level surfaces with a maximum angle of tilt 4°. Please remember

that the fixing screw and washer may also require support if the bearing surface is out of parallel by more than 1°.

The ball shim has no height adjustment feature.

Order No.	Material	For bolt	d ₁	d ₂	d ₃	h	α app.
62140.W0015	Steel	M 6	25	15	8.5	8.0	4°
62140.W0020	Steel	M10	32	20	13.0	10.0	4°
62140.W0030	Steel	M16	45	30	20.0	12.5	4°
62140.W0040	Steel	M24	58	38	29.0	16.0	4°
62140.W0050	Steel	M30	70	48	36.0	20.0	4°
62140.W0060	Steel	M36	80	61	44.0	20.0	4°
62140.W0080	Steel	M48	105	78	58.0	25.0	4°
62140.W0515	Stainless steel	M 6	25	15	8.5	8.0	4°
62140.W0520	Stainless steel	M10	32	20	13.0	10.0	4°
62140.W0530	Stainless steel	M16	45	30	20.0	12.5	4°
62140.W0540	Stainless steel	M24	58	38	29.0	16.0	4°
62140.W0550	Stainless steel	M30	70	48	36.0	20.0	4°
62140.W0560	Stainless steel	M36	80	61	44.0	20.0	4°
62140.W0580	Stainless steel	M48	105	78	58.0	25.0	4°

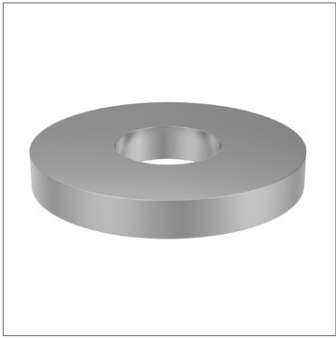

62160

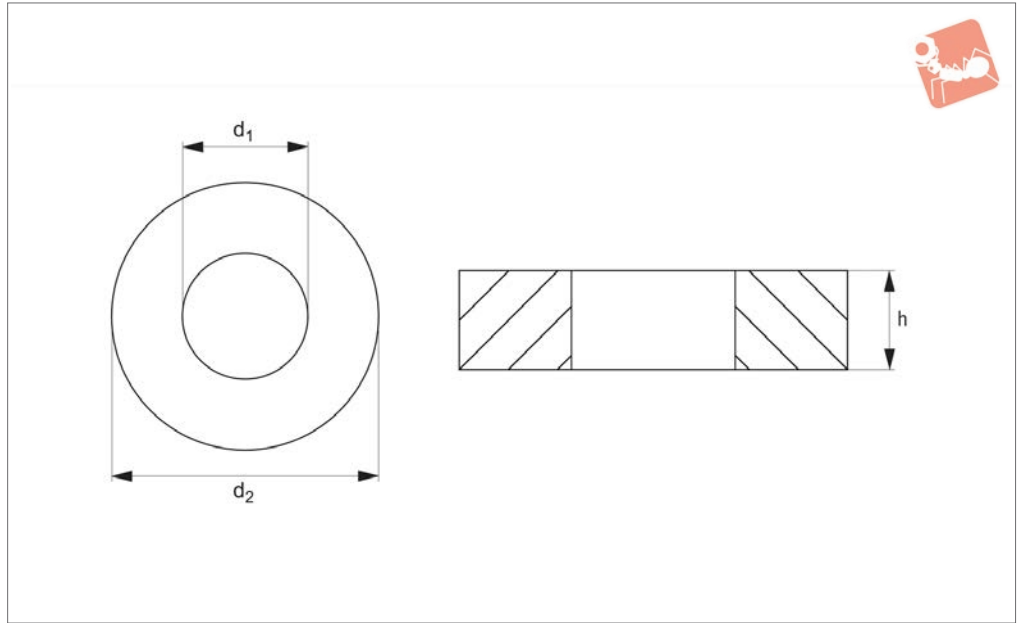

Material

Steel (type 42 CrMo4 V, 1.7225) zinc plated or stainless steel A1 (A4 on request).

Technical Notes

Used to bridge gaps on applications where the height adjustment of an adjuster is

insufficient.

Order No.	Material	For bolt	d_1	d_2	h
62160.W0015	Steel	M 6	6.6	25	4
62160.W0020	Steel	M10	11.0	32	5
62160.W0030	Steel	M16	17.5	45	6
62160.W0040	Steel	M24	26.0	58	8
62160.W0050	Steel	M30	33.0	70	10
62160.W0060	Steel	M36	39.0	80	12
62160.W0080	Steel	M48	52.0	105	16
62160.W0515	Stainless steel	M 6	6.6	25	4
62160.W0520	Stainless steel	M10	11.0	32	5
62160.W0530	Stainless steel	M16	17.5	45	6
62160.W0540	Stainless steel	M24	26.0	58	8
62160.W0550	Stainless steel	M30	33.0	70	10
62160.W0560	Stainless steel	M36	39.0	80	12
62160.W0580	Stainless steel	M48	52.0	105	16



Advantages

- Precision adjusting and re-adjusting.
- Operational under heavy loads.
- Fast installation.
- Greater vertical alignment (from 4 to 105mm).
- Compensation for non-parallel bearing surfaces.
- Suitable for static and dynamic loads.
- Can be anchored to foundation.

Applications

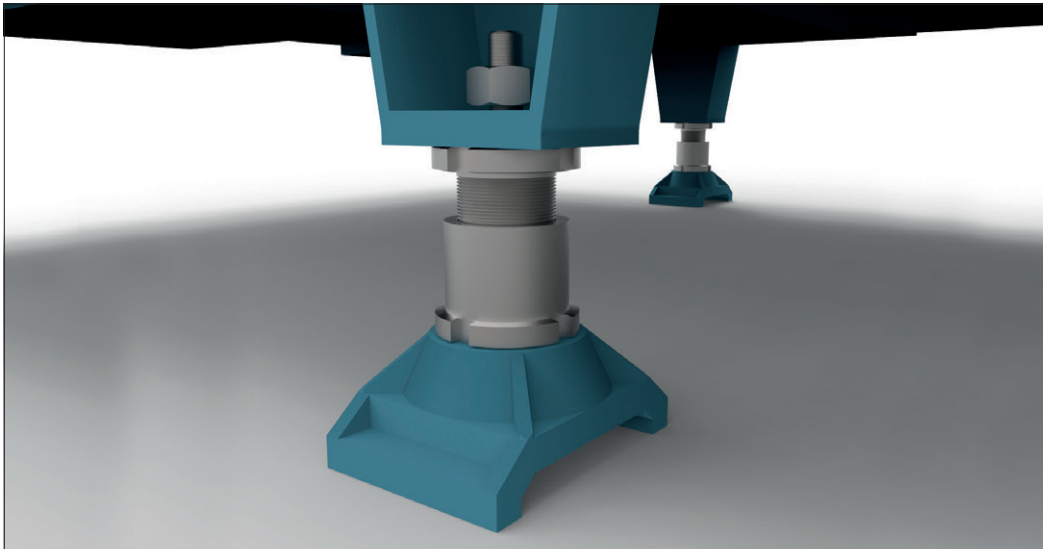

Grounded field mount - Precision Leveller no. 62060 in use on a fully metal encapsulated gas-insulated high voltage switch.

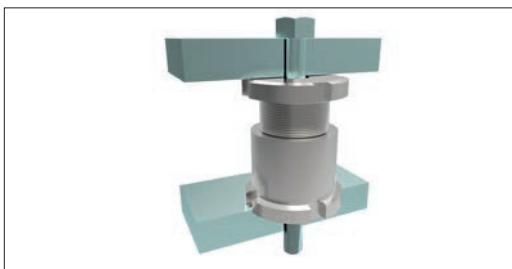

Test stand - Precision Levellers provide adjustment for the connection shaft between motor and transmission.

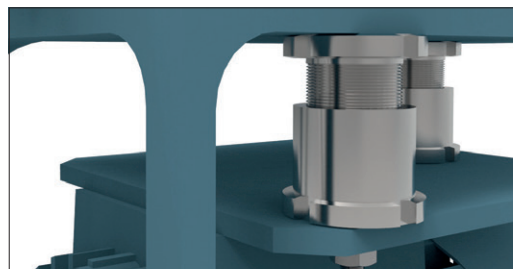

Drive train application - in this application Wixroyd Precision Levellers are used to adjust the rig to ensure correct tension of the V-belt, and to provide full support of the top mounted electric drive motor.

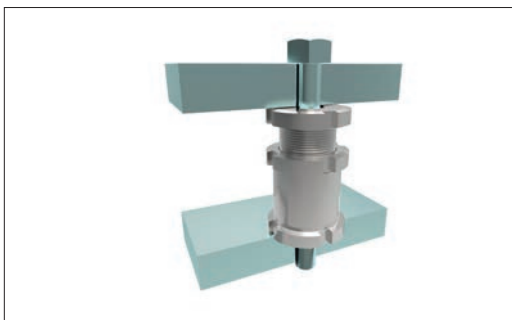

Plummer blocks - even multiple bearings can be levelled easily and precisely, here part no. 62000 is in use.

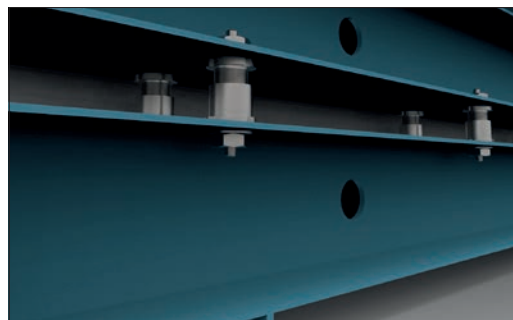

Extruder - precision adjustment of an extruder with leveller no. 62008.



Design features

Wixroyd Precision Levelling Adjusters enable accurate levelling, locating and adjusting of motors, machinery and much more, under heavy loads.

There are three key features to the design, firstly the fine threaded mounting bolt, secondly the threaded nut base and thirdly the end-stop. The fine thread of the mounting bolt and base provides precise adjustment, as well as easy re-adjustment by means of a hook spanner to DIN 1810A, see part no. 95400.

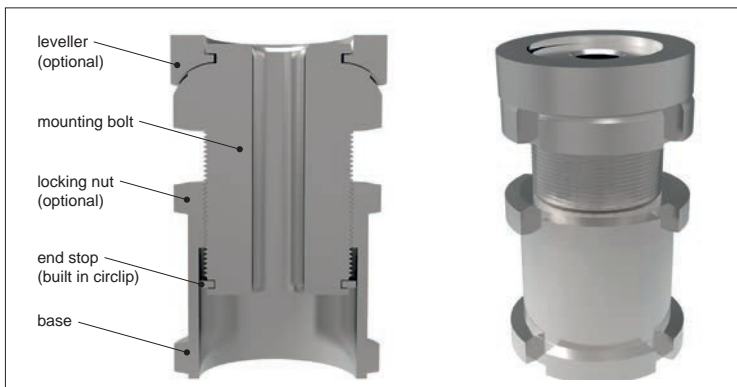

Product range



62000 - Designed for applications with limited space - height adjustment is between 4 and 14mm.



62040 - Designed for applications requiring both height adjustment (from 4 to 14mm) and precise adjustment of non-parallel surfaces, with a maximum angle of tilt 4°.



62060 - Designed for applications where a wide adjustment range is required - height adjustment equal to 15 to 55mm.



62080 - Designed for applications with a dynamic load, or where no fasteners are used. The locknut enables locking of the adjuster in the pre-set position.



62100 - For applications requiring both height adjustment (from 15 to 55mm) and precise adjustment of non-parallel surfaces, with a max. angle of tilt 4°.



62120 - The same features as part number 62100, but with the added feature of a locknut to fix adjuster in any position.



62140/62160 - Designed for applications requiring precise adjustment of non-parallel surfaces, with a maximum angle tilt 4°. The ball shim has no height adjustment feature.

Adjusters vs. levellers

	Precision adjusters				Precision levellers			
Features	62000	62002	62040	62042	62060	62080	62100	62120
Adjustment travel 4-14mm	✓	✓	✓	✓				
Adjustment travel 15-55mm					✓	✓	✓	✓
Lock nut		✓		✓		✓		✓
Slope adjustment up to 4°			✓	✓			✓	✓
Captive screw feature	✓	✓	✓	✓	✓	✓	✓	✓