

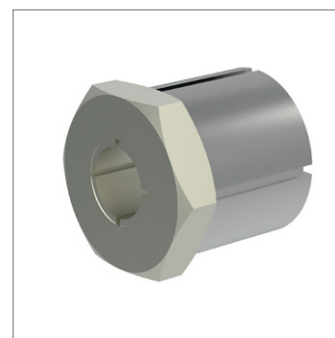

# Tapered Shaft Hubs non-locking

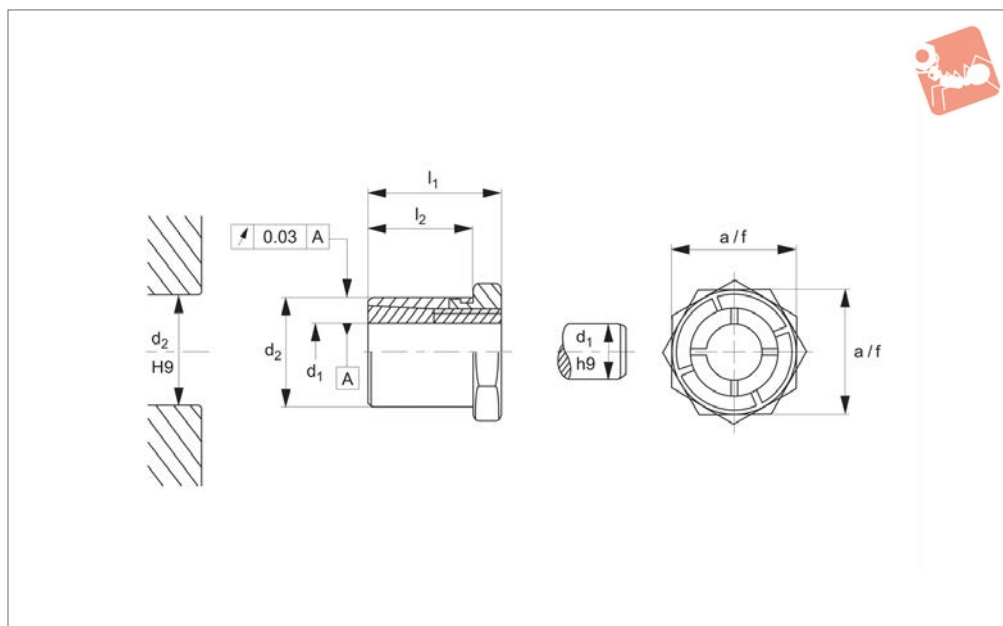

## Shaft Hubs



**38400**

SHAFT HUBS

### Material

Inner part: steel, blackened. Outer part: steel, galvanised. Nut: steel, nickel-plated.

### Technical Notes

Ta = tightening torque of nut.

M = transferable torque.

Fa = transferable thrust load.

pw = surface pressure of shaft.

pn = surface pressure of hub.

The rotational accuracy is 0,03mm.

Please refer to technical pages for mounting instructions.

### Tips

These self-centering and non-floating

tapered shaft hubs are used to easily and effectively achieve shaft/hub joints of machine elements such as sprocket wheels, gear wheels, belt pulleys, cams, levers etc. For special fork wrench see part 38420. W0814- .W0865.

Order No.	Finish	d <sub>1</sub>	d <sub>2</sub>	l <sub>1</sub>	l <sub>2</sub>	A/F	M Nm max.	pn N/mm <sup>2</sup> max.	pw N/mm <sup>2</sup> max.	Ta Nm max.	F <sub>a</sub> kN max.	Weight g
38400.W0005	Without Lock Nut	5	14	19	15	14	10.1	96	264	9.9	4.0	20
38400.W0006	Without Lock Nut	6	14	19	15	14	12.1	96	220	9.9	4.0	19
38400.W0008	Without Lock Nut	8	16	22	17	16	23.4	91	179	16.9	5.8	26
38400.W0009	Without Lock Nut	9	20	24	19	22	43.7	115	245	34.9	9.7	47
38400.W0010	Without Lock Nut	10	20	24	19	22	48.6	115	221	34.9	9.7	46
38400.W0011	Without Lock Nut	11	22	24	19	22	59.9	117	225	43.8	10.9	51
38400.W0012	Without Lock Nut	12	22	24	19	22	65.3	117	206	43.8	10.9	49
38400.W0014	Without Lock Nut	14	26	28	22	27	93.0	99	178	65.0	13.3	83
38400.W0015	Without Lock Nut	15	26	28	22	27	99.0	99	166	65.0	13.3	78
38400.W0016	Without Lock Nut	16	26	28	22	27	106.0	99	156	65.0	13.3	73
38400.W0018	Without Lock Nut	18	35	36	27	36	223.0	125	224	161.0	24.8	201
38400.W0019	Without Lock Nut	19	35	36	27	36	235.0	125	212	161.0	24.8	189
38400.W0020	Without Lock Nut	20	35	36	27	36	248.0	125	201	161.0	24.8	186
38400.W0022	Without Lock Nut	22	42	41	30	46	349.0	110	197	250.0	31.8	346
38400.W0024	Without Lock Nut	24	42	41	30	46	381.0	110	180	250.0	31.8	326
38400.W0025	Without Lock Nut	25	42	41	30	46	397.0	110	173	250.0	31.8	315
38400.W0028	Without Lock Nut	28	47	44	33	50	565.0	110	174	355.0	40.4	403
38400.W0030	Without Lock Nut	30	47	44	33	50	605.0	110	162	355.0	40.4	378
38400.W0032	Without Lock Nut	32	55	51	38	55	764.0	102	166	490.0	47.8	632
38400.W0035	Without Lock Nut	35	55	51	38	55	836.0	102	151	490.0	47.8	571
38400.W0038	Without Lock Nut	38	62	58	43	65	1179.0	111	159	720.0	62.1	897
38400.W0040	Without Lock Nut	40	62	58	43	65	1241.0	111	151	720.0	62.1	842

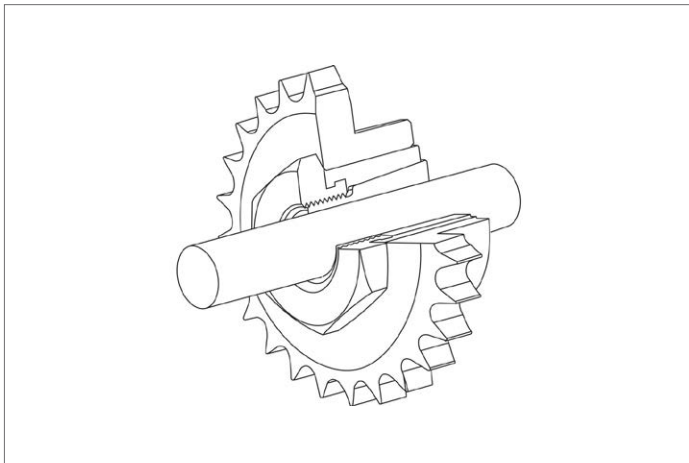



# Tapered Shaft Hubs with lock nut



## Shaft Hubs

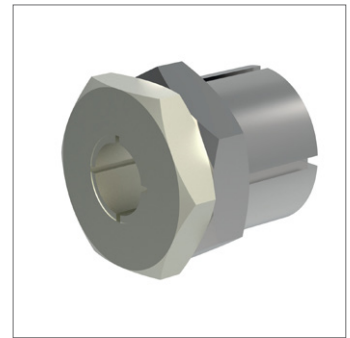
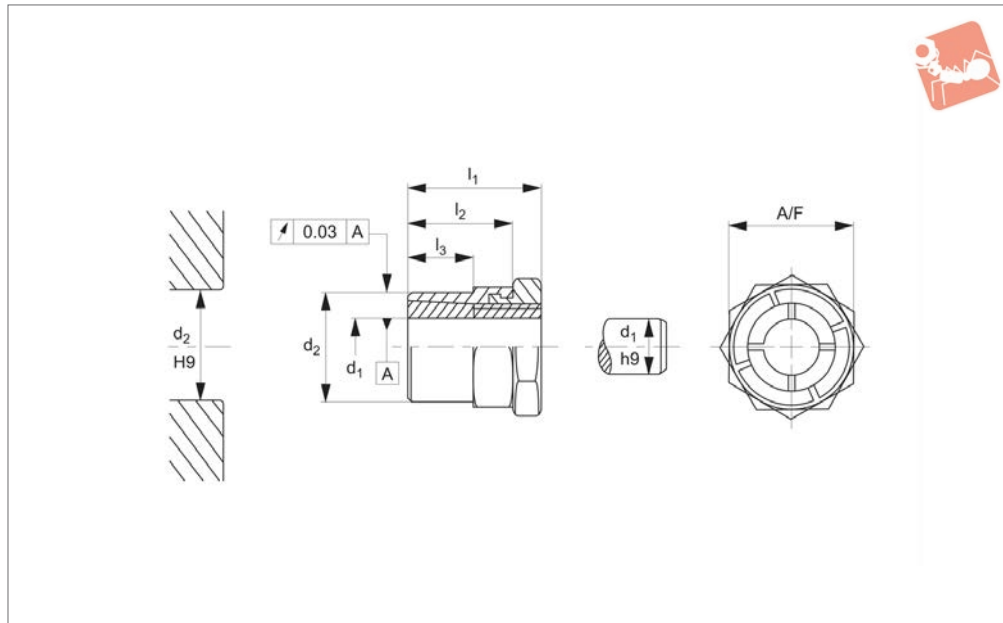

**38420**

SHAFT HUBS

### Material

Inner part: steel, nickel plated.  
Outer part: steel, galvanised.  
Nut: steel, nickel-plated.

### Technical Notes

Ta = tightening torque of nut.  
M = transferable torque.  
Fa = transferable thrust load.

pw = surface pressure of shaft.  
pn = surface pressure of hub.  
Rotational accuracy is 0,3mm.  
Please note special fork wrench is required for mounting, wrench thickness is equal to l2 - l3.

### Tips

These self-centering and non-floating

tapered shaft hubs are used to easily and effectively achieve shaft/hub joints of machine elements such as sprocket wheels, gear wheels, belt pulleys, cams, levers etc. The lock nut enables locking of the shaft-hub joint, where free rotating shafts are used.

Order No.	Finish	d <sub>1</sub>	d <sub>2</sub>	l <sub>1</sub>	l <sub>2</sub>	l <sub>3</sub>	A/F	M Nm max.	pn N/mm <sup>2</sup> max.	pw N/mm <sup>2</sup> max.	Ta Nm max.	F <sub>a</sub> kN max.	Weight g
38420.W0105	With Lock Nut	5	12	19	15	9	14	10.1	119	264	9.9	4.0	18
38420.W0106	With Lock Nut	6	12	19	15	9	14	12.1	119	220	9.9	4.0	17
38420.W0108	With Lock Nut	8	14	22	17	11	16	23.4	121	179	16.9	5.8	23
38420.W0109	With Lock Nut	9	18	24	19	12	22	43.7	127	245	34.9	9.7	47
38420.W0110	With Lock Nut	10	18	24	19	12	22	48.6	127	221	34.9	9.7	46
38420.W0111	With Lock Nut	11	20	24	19	12	22	59.9	128	225	43.8	10.9	47
38420.W0112	With Lock Nut	12	20	24	19	12	22	65.3	128	206	43.8	10.9	45
38420.W0114	With Lock Nut	14	24	28	22	15	27	93.0	107	178	65.0	13.3	78
38420.W0115	With Lock Nut	15	24	28	22	15	27	99.0	107	166	65.0	13.3	75
38420.W0116	With Lock Nut	16	24	28	22	15	27	106.0	107	156	65.0	13.3	70
38420.W0118	With Lock Nut	18	30	36	27	17	36	223.0	145	224	161.0	24.8	179
38420.W0119	With Lock Nut	19	30	36	27	17	36	235.0	145	212	161.0	24.8	169
38420.W0120	With Lock Nut	20	30	36	27	17	36	248.0	145	201	161.0	24.8	213
38420.W0122	With Lock Nut	22	38	41	30	20	46	349.0	122	197	250.0	31.8	341
38420.W0124	With Lock Nut	24	38	41	30	20	46	381.0	122	180	250.0	31.8	320
38420.W0125	With Lock Nut	25	38	41	30	20	46	397.0	122	173	250.0	31.8	310
38420.W0128	With Lock Nut	28	42	44	33	23	50	565.0	123	174	355.0	40.4	370
38420.W0130	With Lock Nut	30	42	44	33	23	50	605.0	123	162	355.0	40.4	348
38420.W0132	With Lock Nut	32	50	51	38	28	55	764.0	112	166	490.0	47.8	555
38420.W0135	With Lock Nut	35	50	51	38	28	55	836.0	112	151	490.0	47.8	501
38420.W0814	Special Fork Wrench	-	-	-	-	-	14	-	-	-	-	-	45
38420.W0816	Special Fork Wrench	-	-	-	-	-	16	-	-	-	-	-	72
38420.W0822	Special Fork Wrench	-	-	-	-	-	22	-	-	-	-	-	195
38420.W0827	Special Fork Wrench	-	-	-	-	-	27	-	-	-	-	-	195
38420.W0836	Special Fork Wrench	-	-	-	-	-	36	-	-	-	-	-	428
38420.W0846	Special Fork Wrench	-	-	-	-	-	46	-	-	-	-	-	610
38420.W0850	Special Fork Wrench	-	-	-	-	-	50	-	-	-	-	-	870
38420.W0855	Special Fork Wrench	-	-	-	-	-	55	-	-	-	-	-	1125



Order No.	Finish	$d_1$	$d_2$	$l_1$	$l_2$	$l_3$	A/F	M Nm max.	pn N/mm <sup>2</sup> max.	pw N/mm <sup>2</sup> max.	Ta Nm max.	F <sub>a</sub> kN max.	Weight g
38420.W0865	Special Fork Wrench	-	-	-	-	-	65	-	-	-	-	-	1295

SHAFT HUBS

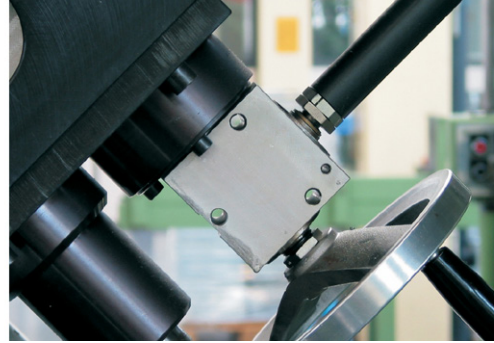
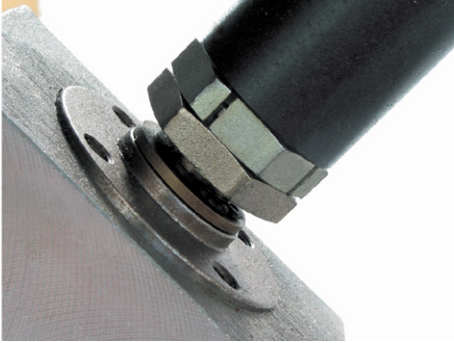



# Wixroyd Tapered Shaft Hubs

## mounting and assembly instructions

38400 - 38420  
Positioning Elements

SHAFT HUBS

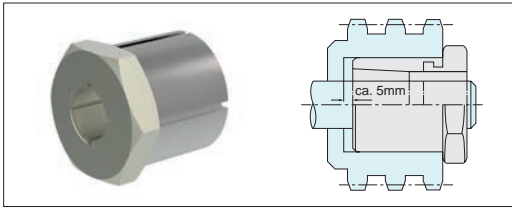

Tapered shaft hub with hexagon nut

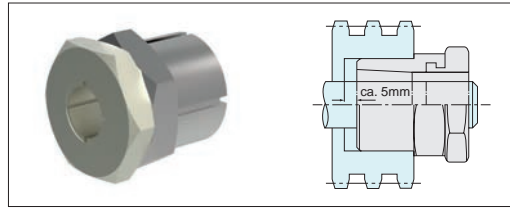

Tapered shaft hub with hexagon nut and lock nut

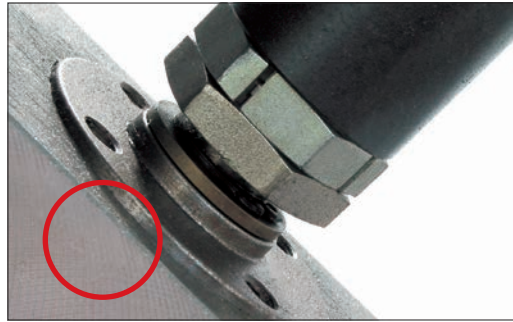
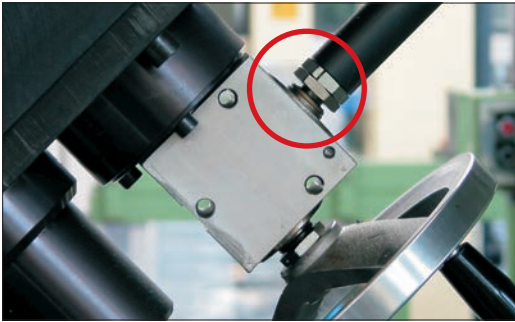

### Applications

By using tapered shaft hubs, sprocket wheels, gear wheels, belt pulleys, cams, levers etc. can be easily and efficiently installed.

Tapered shaft hubs are available with or without lock nuts.

If, on mounting, the hub sits close to a collar, an axial offset is not possible. In this case, only 60% of the forces mentioned in the charts can be transmitted.

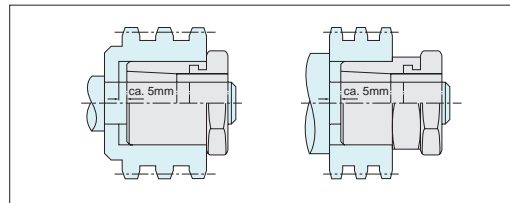

### No Axial Shift

When using this method, the tapered shaft hub which is tightened first transmits 100% of the forces mentioned in the charts. When tightening the second tapered shaft hub, an axial offset of the hub is not possible. Therefore, this tapered shaft hub is able to transmit only 60% of the forces.

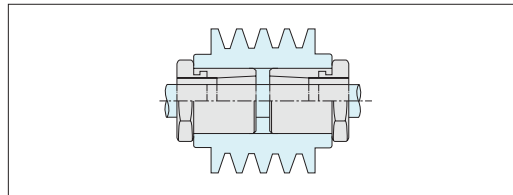

### Two Tapered Shaft Hubs in One Hub

## Assembly and Disassembly

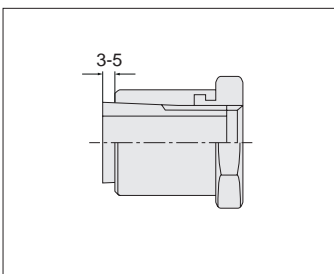

1. Rotate nut to the left until the inner part protrudes approx. 3-5mm over the outer.

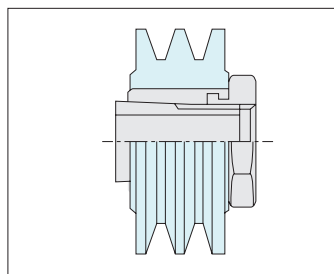

2. Install tapered shaft hub in the hub hole.

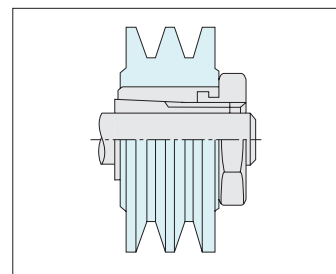

3. Slightly tighten the nut when located in the desired position. Compensate the axial offset thus produced with a soft-face mallet. Tighten the tapered shaft hub.

### Assembly

The contact surface of the shaft and the hub must be free from oil and dirt.

1. Release tapered shaft hub by turning the nut to the left until the inner part protrudes approx. 3-5mm over the outer part.

### Disassembly



### Simultaneous Exposure to Different Forces

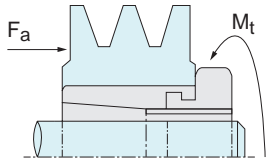

If torque ( $M_t$ ) and axial forces ( $F_a$ ) are transmitted simultaneously, a resultant total torque ( $M_r$ ) is obtained which must be less than or equal to the maximum torque ( $M_{max}$ ) indicated in the charts. ( $M_r \leq M_{max}$ ).

$$M_r = \sqrt{M_t^2 + (F_a \times 2 \times 1000)^2 \times v}$$

$M_r$  = Resultant total torque     $d_1$  = Shaft diameter  
 $M_t$  = Torque     $v$  = Safety factor  
 $F_a$  = Axial force

**Example:**

Shaft hub 38420.W0125

$M_t$  = 150Nm  
 $F_a$  = 5kN  
 $d_1$  = 25mm  
 $v$  = 2

$$M_r = \sqrt{150^2 \text{Nm}^2 + (5000 \text{N} \times 2 \times 1000 \text{mm/m})^2 \times 2} = 325 \text{Nm}$$

A maximum torque ( $M_{max}$ ) of 520 Nm is transmitted by the tapered shaft hub 38420.W0125. The forces can be transmitted because  $M_r$  (325 Nm) is less than  $M_{max}$ .

### Outside Diameter of Hub and Inside Diameter to Hollow Shaft

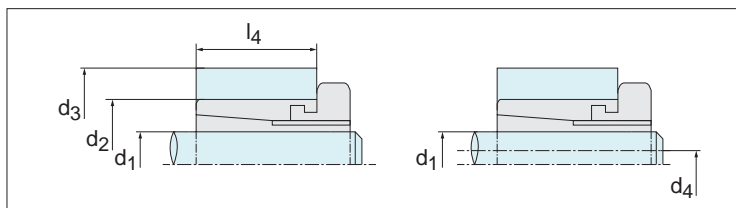

When fitting tapered shaft hubs, the outside diameter of the hub and the inside diameter of the hollow shaft have to be considered.

#### Smallest possible outside diameter of hub and inside diameter of hollow shaft

$$d_3 \geq d_2 \times \sqrt{\frac{R_e + P_N \times C_N}{R_e - P_N \times C_N}} \quad [\text{mm}]$$

$$d_4 \leq d_1 \times \sqrt{\frac{R_e - 2P_W}{R_e (R_p)}} \quad [\text{mm}]$$

$d_1$  = Shaft diameter  
 $d_2$  = Hub hole  
 $d_3$  = Outside diameter of hub  
 $d_4$  = Inside diameter of hollow shaft  
 $R_e$  = Apparent yielding point  
 $R_{p0,2} R_{p0,1}$  = Permanent elongation limit

$P_N$  = Surface pressure hub  
 $P_W$  = Surface pressure shaft  
 $C_N$  = Factor [is "1", if the hub length is  $\geq$  the fitting length of the tapered shaft hub ( $L_N \geq L_2$ )]

**Example:**

Tapered shaft hub 38400.W0025, hub material GG25;

Tapered shaft hub 38400.W0025, hub material CK45;

$R_{p0,1}$  = 165Nmm<sup>2</sup>  
 $C_N$  = 1

$R_e$  = 380Nmm<sup>2</sup>  
 $C_N$  = 1

$$d_3 \geq 42 \text{mm} \times \sqrt{\frac{165 \text{Nmm}^2 + 103 \text{Nmm}^2 \times 1}{165 \text{Nmm}^2 - 103 \text{Nmm}^2 \times 1}} \geq 87,4 \text{mm}$$

$$d_4 \leq 25 \text{mm} \times \sqrt{\frac{380 \text{Nmm}^2 - 2 \times 174 \text{Nmm}^2}{380 \text{Nmm}^2}} \leq 7,2 \text{mm}$$

### Material Chart

Diameter	Material									
	St 37-2 Ust 37-2	St 50-2	Ck 35	Ck 45	11 SMn 30 11SMn Pb 30	GG 15	GG 20	GG 25	GGG-40	AlMg 3 F 25
	Re	Re	Re	Re	Re	Rp 0,1	Rp 0,1	Rp 0,1	Rp 0,2	Re
16 < d <sub>1</sub> ≤ 40	225	285	320	380	375	90	130	165	250	180
40 < d <sub>1</sub> ≤ 100	205	265	260	300	245	90	130	165	250	180