

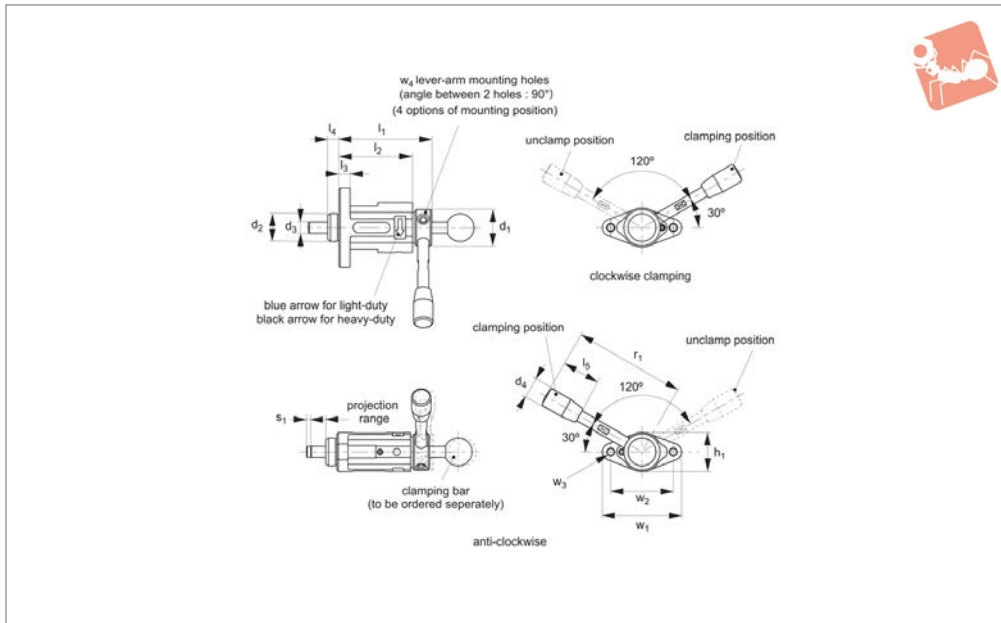

# Vertical Acting Thrust Clamps

# Adjustable Vertical Clamps



**12615**

ADJUSTABLE VERTICAL CLAMPS

### Material

Body/lever arm: steel (C45), black oxide finish.

Cam: steel (C45), carburized-hardened, black oxide finish.

Handle: phenolic plastic, black matt. Clamping handle is not included.

### Technical Notes

Can be used in both vertical and horizontal

clamping applications.

Spring-loaded clamp that provides constant clamping force.

Long clamping-bar projection range allows clamping of a recessed part.

When using your own clamping bar, ensure that the diameter is finished to a H9 or better tolerance.

### Tips

When a reaction force (F) becomes greater than clamping force, the clamping bar slides back, unclamping the part.

Order No.	Type	Clamping direction	d <sub>1</sub>	d <sub>2</sub>	d <sub>3</sub>	d <sub>4</sub>	h <sub>1</sub>	l <sub>1</sub>	l <sub>2</sub>	l <sub>3</sub>	Weight g
12615.W0008	Light Duty	Clockwise	26	20	8	14	28	68.5	53	8	330
12615.W0012	Light Duty	Clockwise	36	30	12	21	40	90.7	72	12	930
12615.W0208	Light Duty	Clockwise	26	20	8	14	28	68.5	53	8	330
12615.W0212	Light Duty	Clockwise	36	30	12	21	40	90.7	72	12	950
12615.W0108	Heavy Duty	Anti Clockwise	26	20	8	14	28	68.5	53	8	330
12615.W0112	Heavy Duty	Anti Clockwise	36	30	12	21	40	90.7	72	12	930
12615.W0308	Heavy Duty	Anti Clockwise	26	20	8	14	28	68.5	53	8	330
12615.W0312	Heavy Duty	Anti Clockwise	36	30	12	21	40	90.7	72	12	950

Order No.	l <sub>4</sub>	l <sub>5</sub>	r <sub>1</sub>	w <sub>1</sub>	w <sub>2</sub>	w <sub>3</sub>	w <sub>4</sub>	Clamping stroke s <sub>1</sub>	Handle load N max.	Clamping force kN max.	Clamping releasing force kN
12615.W0008	8	28	80	57	45	M 6x1 (Pre-drill 5,2)	M 5x0,8	1.5	40	0.2	F>0,2
12615.W0012	12	50	132	85	65	M10x1,5 (Pre-drill 8,5)	M 6x1	2.3	100	0.7	F<0,7
12615.W0208	8	28	80	57	45	M 6x1 (Pre-drill 5,2)	M 5x0,8	1.5	80	0.5	F>0,5
12615.W0212	12	50	132	85	65	M10x1,5 (Pre-drill 8,5)	M 6x1	2.3	150	1.4	F>1,4
12615.W0108	8	28	80	57	45	M 6x1 (Pre-drill 5,2)	M 5x0,8	1.5	40	0.2	F>0,2
12615.W0112	12	50	132	85	65	M10x1,5 (Pre-drill 8,5)	M 6x1	2.3	100	0.5	F<0,7
12615.W0308	8	28	80	57	45	M 6x1 (Pre-drill 5,2)	M 5x0,8	1.5	80	0.5	F>0,5



Order No.	$l_4$	$l_5$	$r_1$	$w_1$	$w_2$	$w_3$	$w_4$	Clamping stroke $s_1$	Handle load N max.	Clamping force kN max.	Clamping releasing force kN
<b>12615.W0312</b>	12	50	132	85	65	M10x1,5 (Pre-drill 8,5)	M 6x1	2.3	150	1.4	F>1,4

ADJUSTABLE VERTICAL CLAMPS

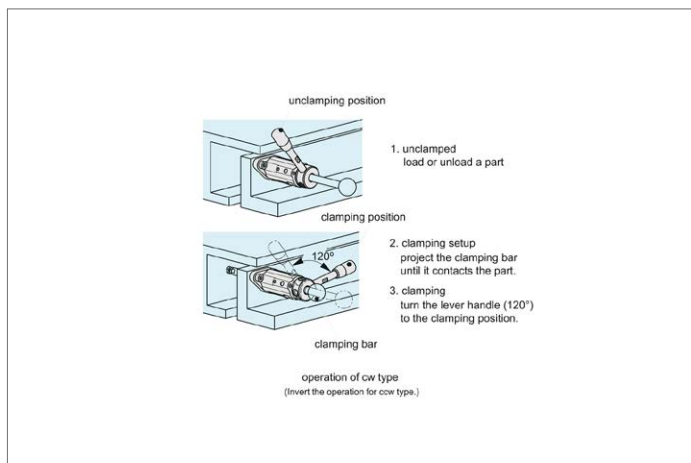

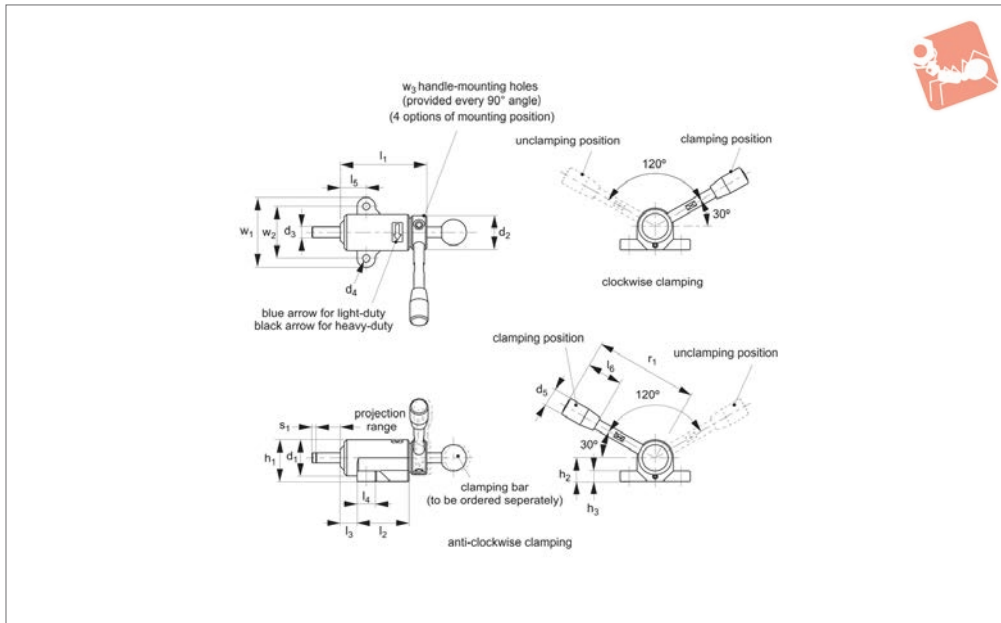

## 12616.1

ADJUSTABLE VERTICAL CLAMPS

### Material

Body/lever arm: steel (C45), black oxide finish.

Cam: steel (C45), carburized-hardened, black oxide finish.

Handle: phenolic plastic, black matt.

### Technical Notes

Can be used in both vertical and horizontal

clamping applications.

Spring-loaded clamp that provides constant clamping force.

Long clamping-bar projection range allows clamping of a recessed part.

When using your own clamping bar, ensure that the diameter is finished to a H9 or better tolerance.

### Tips

When the applied u-clamp force (F) becomes greater than clamping force, the clamping bar slides back, unclamping the part.

Order No.	Type	Clamping direction	d <sub>1</sub>	d <sub>2</sub>	d <sub>3</sub>	d <sub>4</sub>	d <sub>5</sub>	h <sub>1</sub>	h <sub>2</sub>	h <sub>3</sub>	Weight g
12616.W0008	Light Duty	Clockwise	28	26	8	5.5	14	32	18	8	330
12616.W0012	Light Duty	Clockwise	40	36	12	9.0	21	45	25	12	910
12616.W0208	Heavy Duty	Clockwise	28	26	8	5.5	14	32	18	8	330
12616.W0212	Heavy Duty	Clockwise	40	36	12	9.0	21	45	25	12	910
12616.W0108	Light Duty	Anti Clockwise	28	26	8	5.5	14	32	18	8	330
12616.W0112	Light Duty	Anti Clockwise	40	36	12	9.0	21	45	25	12	910
12616.W0308	Heavy Duty	Anti Clockwise	28	26	8	5.5	14	32	18	8	330
12616.W0312	Heavy Duty	Anti Clockwise	40	36	12	9.0	21	45	25	12	910

Order No.	l <sub>1</sub>	l <sub>2</sub>	l <sub>3</sub>	l <sub>4</sub>	l <sub>5</sub>	l <sub>6</sub>	r <sub>1</sub>	w <sub>1</sub>	w <sub>2</sub>	w <sub>3</sub>	Clamping stroke s <sub>1</sub>	Handle load N max.	Clamping force kN max.	Clamping releasing force kN
12616.W0008	68.5	40	13	14	20	28	80	54	40	M 5x0,8	1.5	40	0.2	F>0,2
12616.W0012	93.7	55	20	20	30	50	132	80	60	M 6x1	2.3	100	0.7	F>0,7
12616.W0208	68.5	40	13	14	20	28	80	54	40	M 5x0,8	1.5	80	0.5	F>0,5
12616.W0212	93.7	55	20	20	30	50	132	80	60	M 6x1	2.3	150	1.4	F>1,4
12616.W0108	68.5	40	13	14	20	28	80	54	40	M 5x0,8	1.5	40	0.2	F>0,2
12616.W0112	93.7	55	20	20	30	50	132	80	60	M 6x1	2.3	100	0.7	F>0,7



Order No.	$l_1$	$l_2$	$l_3$	$l_4$	$l_5$	$l_6$	$r_1$	$w_1$	$w_2$	$w_3$	Clamping stroke $s_1$	Handle load N max.	Clamping force kN max.	Clamping releasing force kN
<b>12616.W0308</b>	68.5	40	13	14	20	28	80	54	40	M 5x0,8	1.5	80	0.5	F>0,5
<b>12616.W0312</b>	93.7	55	20	20	30	50	132	80	60	M 6x1	2.3	150	1.4	F>1,4

ADJUSTABLE VERTICAL CLAMPS

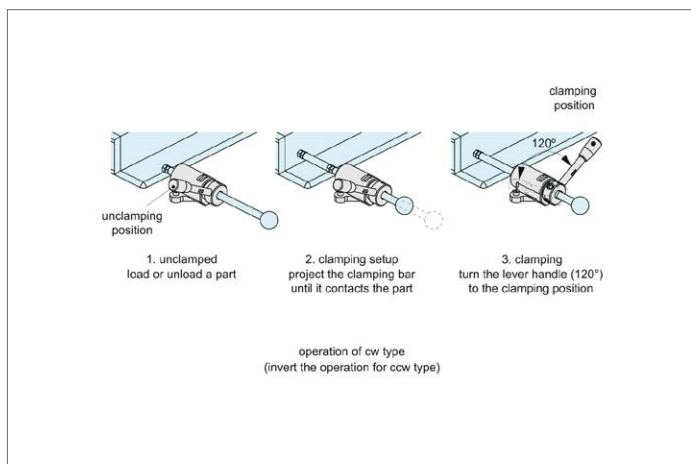



# Handles For Thrust Clamps for 12615 & 12616

## Adjustable Vertical Clamps

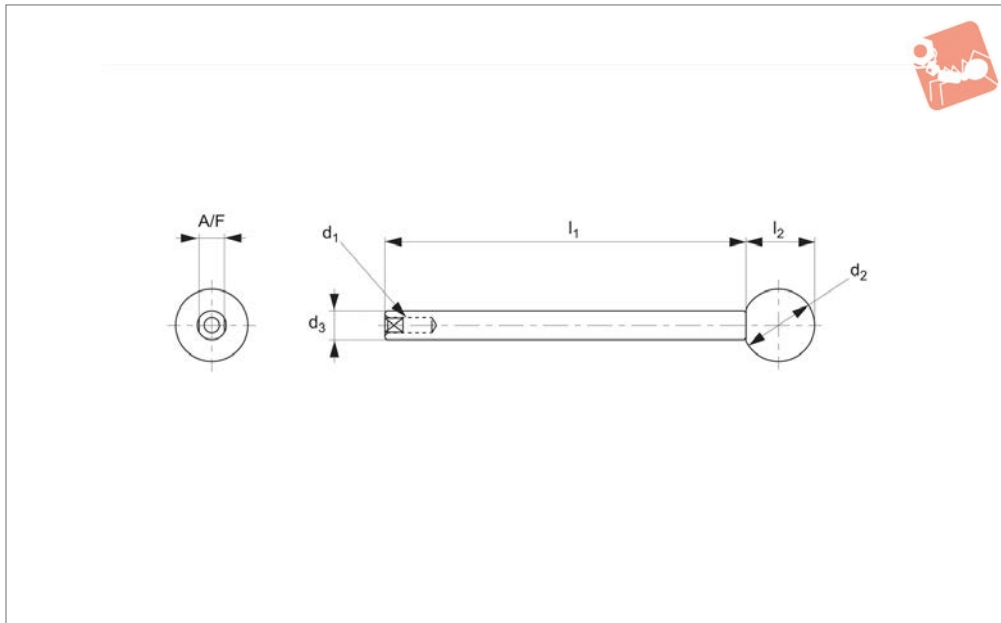

**12616.2**

ADJUSTABLE VERTICAL CLAMPS

### Material

Arm: steel (C45), chrome plated.  
Ball knob: ABS resin black.

### Tips

Can be used with part no's 12615 and 12616.W0008- .W0312.

Order No.	d <sub>1</sub>	d <sub>2</sub>	d <sub>3</sub>	l <sub>1</sub>	l <sub>2</sub>	A/F	Weight g
<b>12616.W0810</b>	M 4x8	20	8	100	19	7	50
<b>12616.W0812</b>	M 4x8	20	8	125	19	7	60
<b>12616.W0815</b>	M 4x8	20	8	150	19	7	70
<b>12616.W1212</b>	M 6x12	25	12	125	24	10	130
<b>12616.W1215</b>	M 6x12	25	12	150	24	10	150
<b>12616.W1220</b>	M 6x12	25	12	200	24	10	190

