

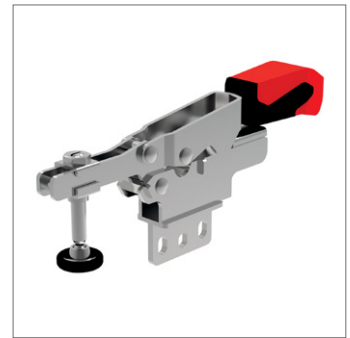

# Auto-Adjust Toggle Clamp

open clamping arm - vertical base

# Auto-Adjust Toggle Clamps

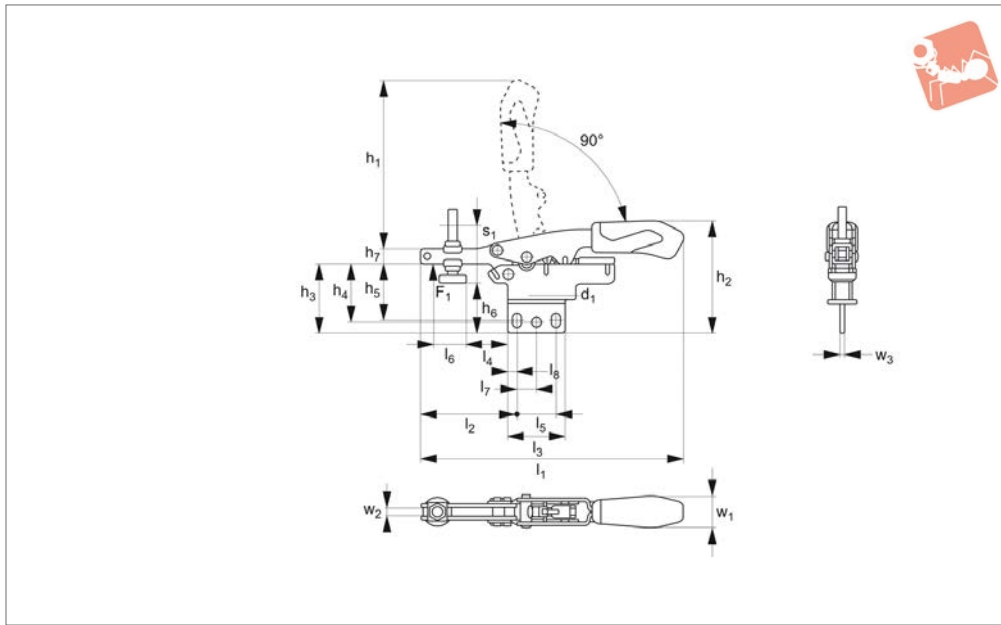

**42609**

AUTO-ADJUST TOGGLE CLAMPS

### Material

Body: steel, zinc plated.  
Ergonomic, soft feel and oil-resistant handle with large grip area.

Supplied complete with zinc plated clamping screw (with rubber pad).

### Technical Notes

Automatically adjusts to suit work-piece height.  
Temperature range -10°C to +80°C.

Order No.	Size	F <sub>1</sub> kN	Automatic height compensation s <sub>1</sub>	Height compensation max.	Clamping screw	h <sub>1</sub>	h <sub>2</sub>	h <sub>3</sub>	h <sub>4</sub>	h <sub>5</sub>	h <sub>6</sub> min.	Weight g
<b>42609.W0020</b>	20	2	20	35	M 6x49	113	73.0	47	39.8	37-40	13.5	272
<b>42609.W0050</b>	50	3	35	40	M 8x50	158	94.5	59	49.0	45-49	27.5	544

Order No.	h <sub>6</sub> max.	h <sub>7</sub>	l <sub>1</sub>	l <sub>2</sub>	l <sub>3</sub>	l <sub>4</sub>	l <sub>5</sub>	l <sub>6</sub>	l <sub>7</sub>	l <sub>8</sub>	w <sub>1</sub>	w <sub>2</sub>	w <sub>3</sub>	d <sub>1</sub>	d <sub>2</sub>
<b>42609.W0020</b>	31	10	173	64.0	38	25.9	26	22	13	6.0	21	6.0	3	5.6	5.6
<b>42609.W0050</b>	38	13	243	106.5	55	38.0	50	35	19	8.5	27	8.2	4	6.5	5.6



### Benefits

- Automatically adapts to workpiece height / width.
- Ideal for small batch sizes.
- Adjustable clamping forces.



### Example Toggle Clamps

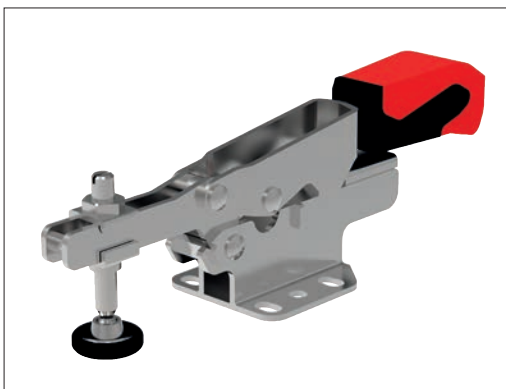

42605 - Horizontal base - vertical acting

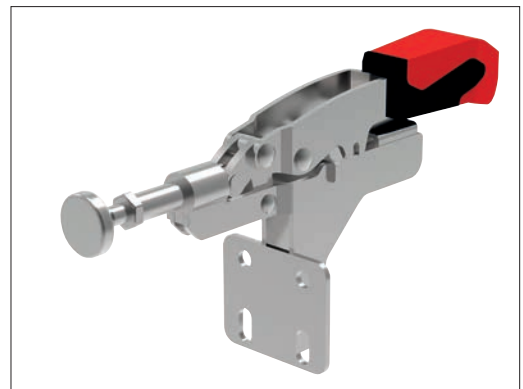

42611 - Push pull type - horizontal acting